

Kit pour porte coulissante en verre 80 Kg MAX  
 Pour baie comprise entre 2330 et 2530 mm  
 Système synchronisé  
 Fixation murale

Kit for sliding glass door 80 Kg MAX  
 Bay between 2330 and 2530 mm  
 Synchronized system  
 Wall fixing

Composition du kit:

- 1 rail aluminium anodisé avec trous de fixation
  - 1 bandeau en aluminium anodisé : L 5.00m
  - 3 clips de fixation bandeau
  - 2 kits montures avec pinces verre et amortisseur
  - 3 butées antidéraillement
  - 2 butées gauches
  - 2 butées droites sans crochet
  - 1 kit synchronisation
  - 1 joint autocollant pour champs de porte
  - 2 embouts d'extrémité de rail
  - 2 guides bas
  - Notice et clés de montage
- Verre non fourni

Composition of the kit:

- 1 anodized aluminum track with mounting holes
  - 1 anodised aluminum pelmet. Length 5.00m
  - 3 pelmet clips
  - 2 gear sets with glass clamps and shock absorber
  - 3 anti-lift devices
  - 2 left end stops
  - 2 right end stops without hook
  - 1 synchronization set
  - 1 seal for door edge
  - 2 anodized aluminum end caps
  - 2 bottom guides
  - Installation instructions and tools
- Glass not supplied

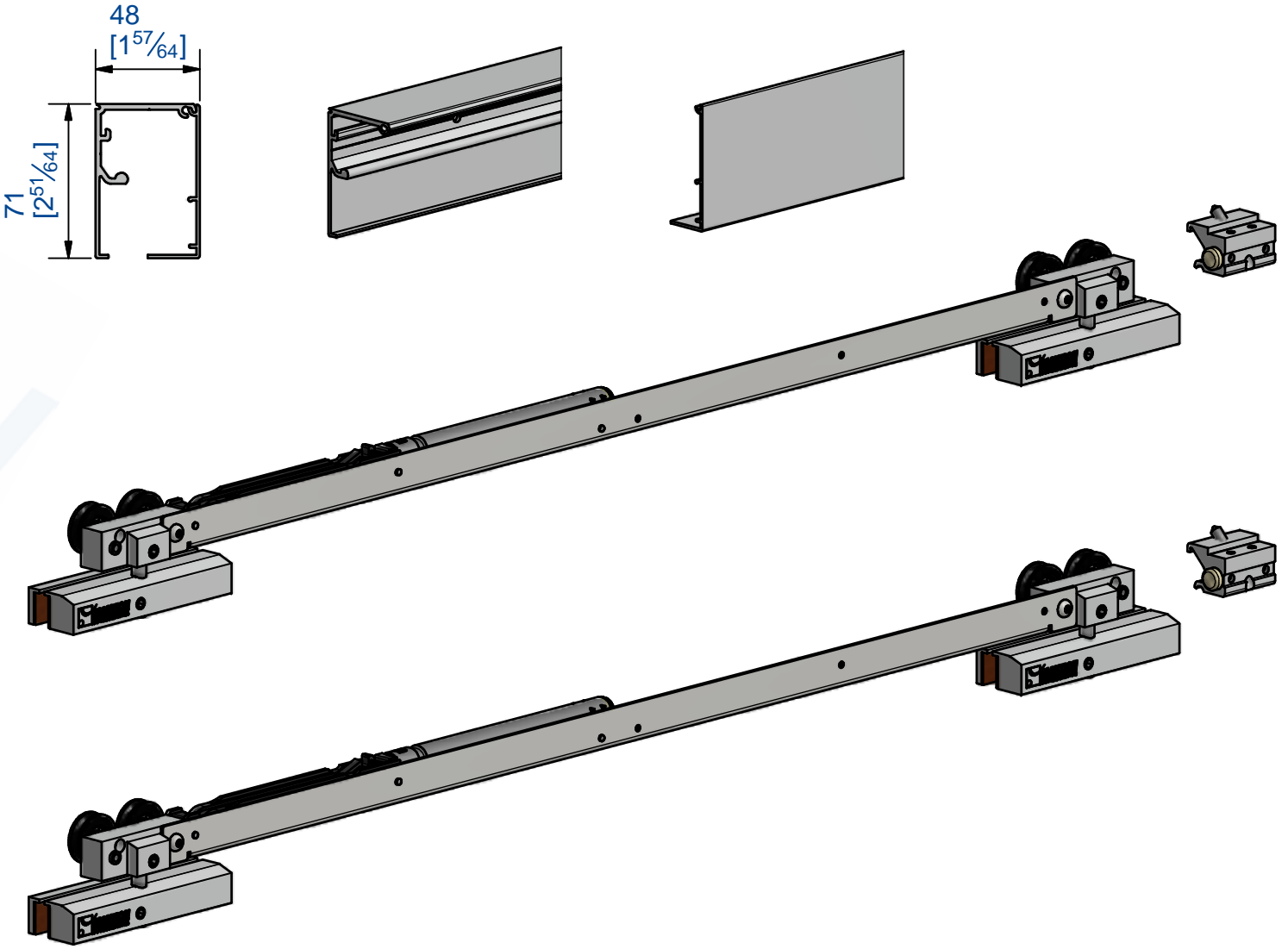
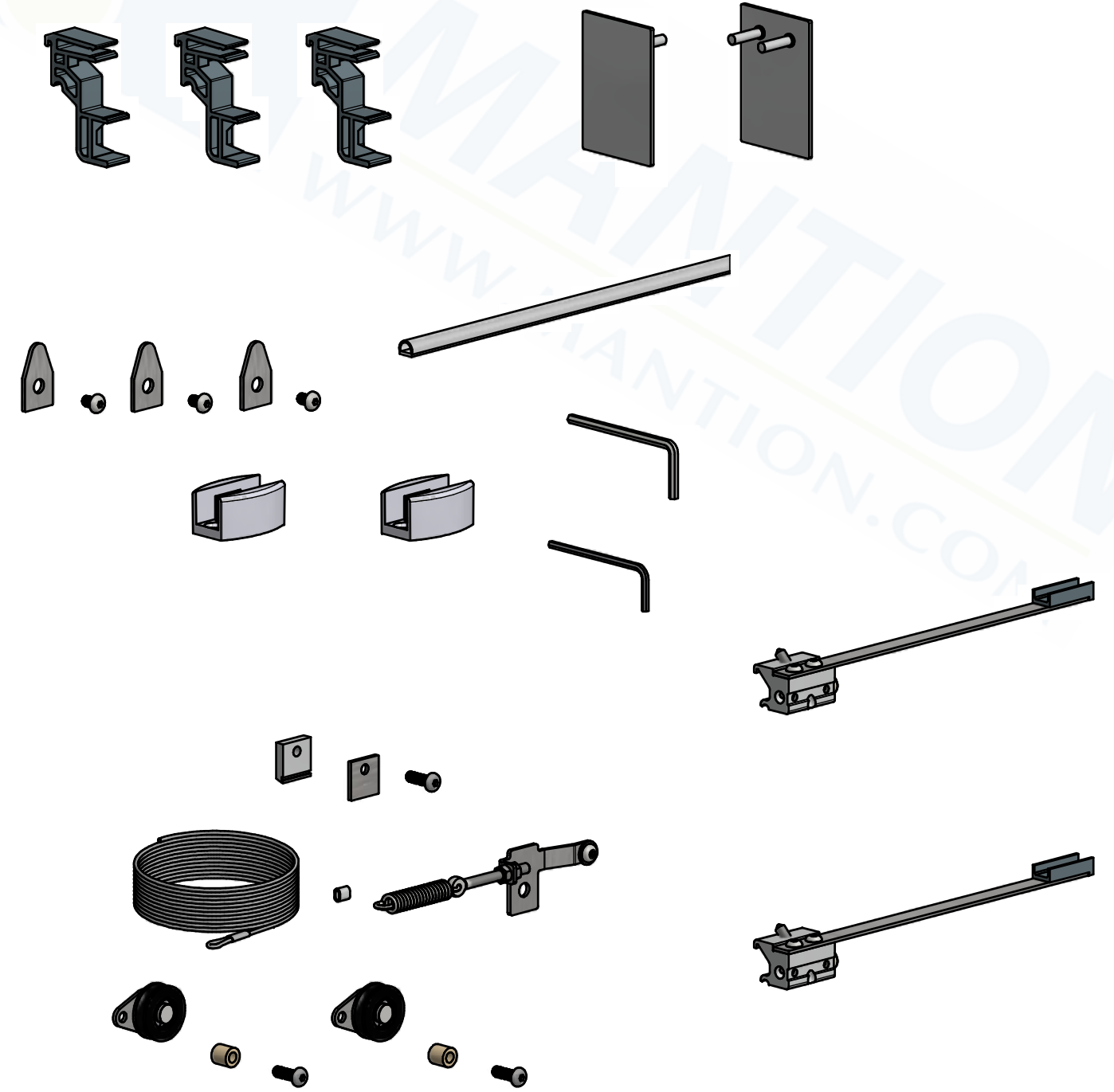

 <p>FERRURES DE PORTES COULISSANTES MANUTENTION PAR MONORAIL</p> <p>7, rue Gay Lussac 25000 BESANCON</p>	<p>Référence Item Nr: <b>GB0120</b></p>	<p>Rail associé Combined track:</p>
---	---	---