

6000  
[236 1/4]

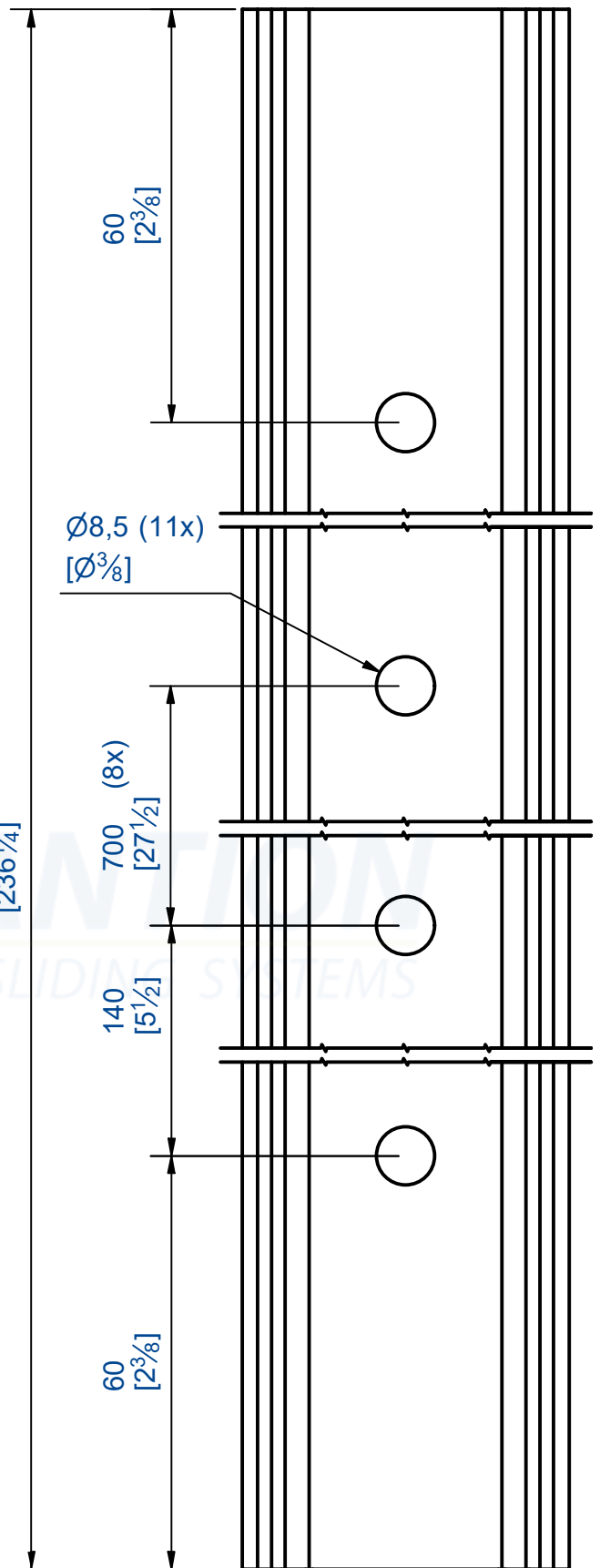

Rail percé 51.5x47.5 - Longueur 6m  
Drilled track 2 x 1 7/8 - Length 6m

$I_{yy}' = 24 \text{ cm}^4$

$I_{xx}' = 25.2 \text{ cm}^4$

$I_{xx}'/v = 9 \text{ cm}^3$

Section = 7.2 cm<sup>2</sup>

Poids / weight = 2 Kg/m

Matière / material : Anodized 20 $\mu$  Aluminium 6060



7, rue Gay Lussac  
25000 BESANCON

Référence  
Item Nr:

**10400A/600**

Rail associé  
Combined track: