

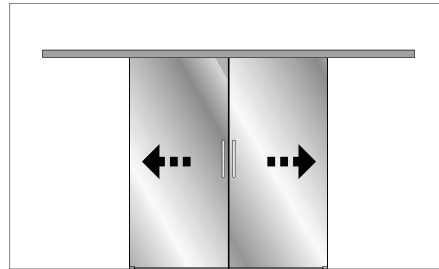

INSTRUCTION DE MONTAGE  
MONTAGEANLEITUNG  
INSTRUCTIONS FOR ASSEMBLY  
INSTRUCCIONES DE MONTAJE

**INTEC**  
**NM\_INTEC\_003**

PORTE D'INTÉRIEUR / INNENTÜR / INTERIOR DOOR / PUERTA DE INTERIOR

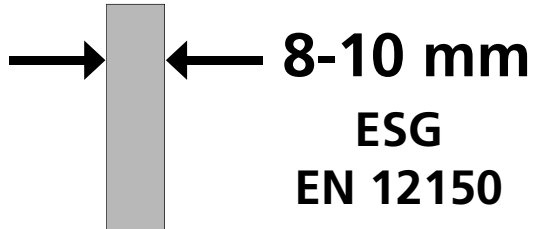

synchronisé - synchronized

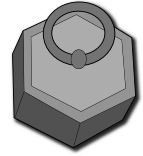

**80 KG**

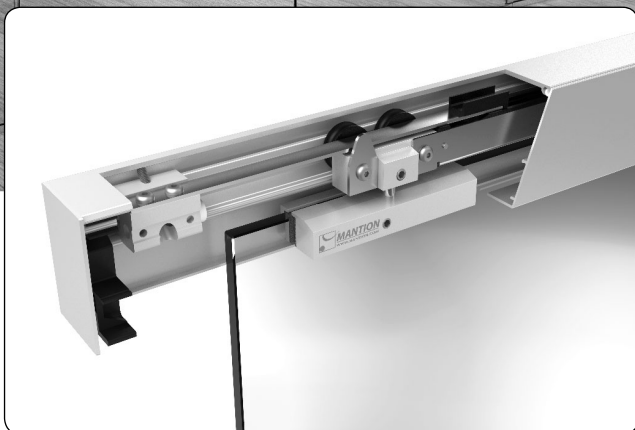

# COMPOSITION - ZUSAMMENSETZUNG - COMPOSICIÓN

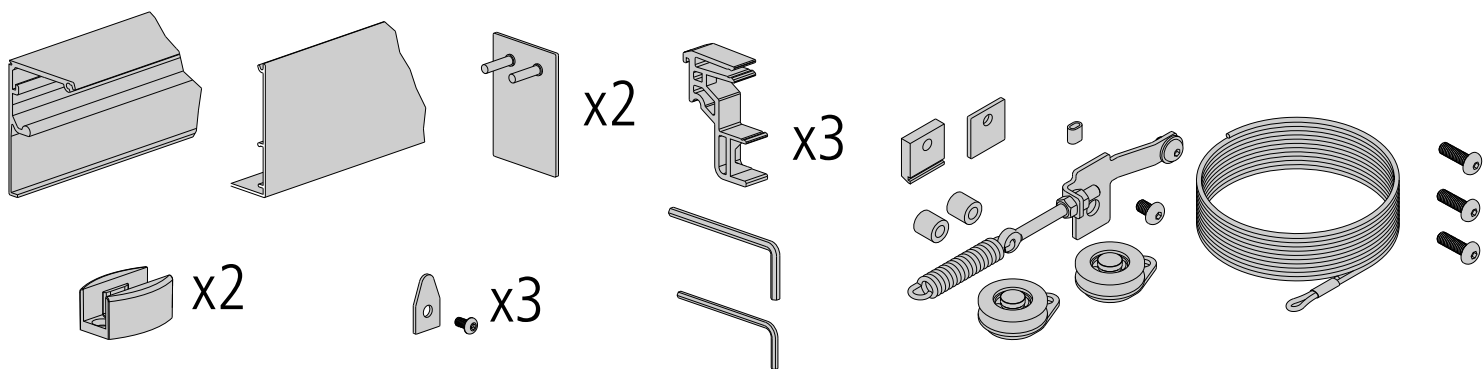

**GB 5002 - GB5004**

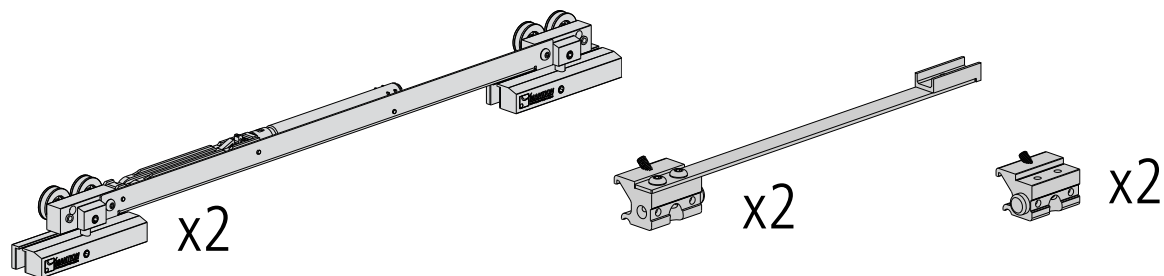

**GB 5003**

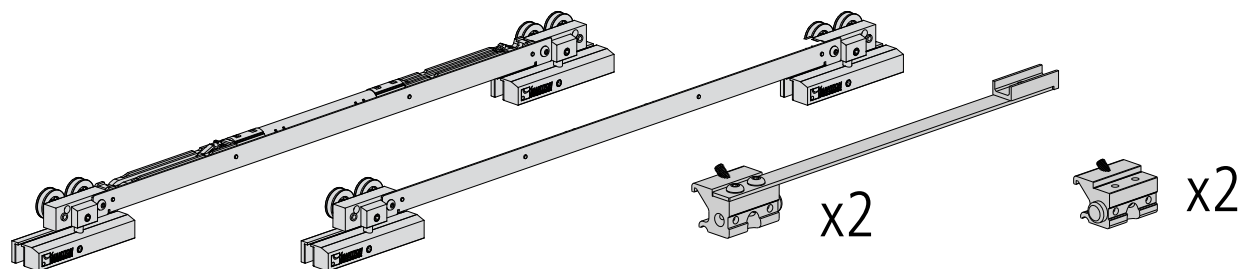

**OPTION**

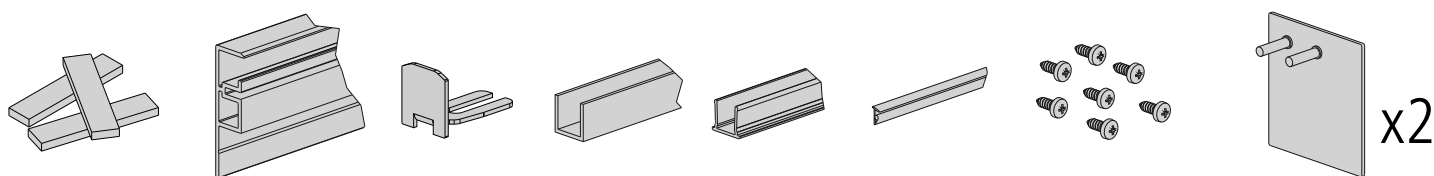

## CONDITIONS DE POSE / MONTAGEBEDINGUNGEN / INSTALLATION REQUIREMENTS / CONDICIONES DE COLOCACION:

- Produit destiné à une utilisation en intérieur / Dieses Produkt ist nur für Innenanwendung geeignet / For indoor use only / Producto para utilización en interior
- Ne pas installer dans des endroits humides / Nicht in feuchten Atmosphären verwenden / Do not install in humid places / No instalar en lugares húmedos
- Le montage doit être effectué par des monteurs qualifiés / Die Montage muss von qualifizierten Handwerkern geführt werden / Installation must be performed by skilled personnel / el montaje tiene que hacerse por instaladores cualificados

## DIMENSIONS / MASSE / SIZING / DIMENSIONES (mm):

Linteau min. / Min. Türsturz / Min. lintel / Dintel min: **71 mm**

Epaisseur panneau / Paneelstärke / Panel thickness / Grueso del panel: **8-10 mm (ESG - EN12150)**

Poids panneau / Paneelgewicht / Panel weight / Peso panel: **80 Kg MAX**

Largeur de panneau minimum / Minimale Feldbreite / Minimum panel width / Ancho del panel mínimo: **710 mm**

## FIXATION MURALE FIXING ON THE WALL WANDBEFESTIGUNG MONTAJE FIJACIÓN A PARED

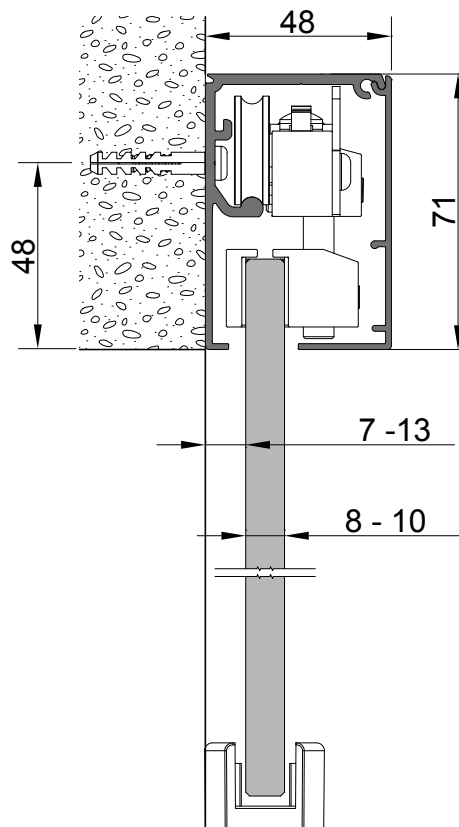

Réf. Kit Set nb / Art.-Nr.	O	R
<b>GB0110</b>	$1330 \leq O < 1530$	$(3004 - O) / 2$
<b>GB0112</b>	$1530 \leq O < 1730$	$(3404 - O) / 2$
<b>GB0114</b>	$1730 \leq O < 1930$	$(3804 - O) / 2$
<b>GB0116</b>	$1930 \leq O < 2130$	$(4204 - O) / 2$
<b>GB0118</b>	$2130 \leq O < 2330$	$(4604 - O) / 2$
<b>GB0120</b>	$2330 \leq O < 2530$	$(5004 - O) / 2$

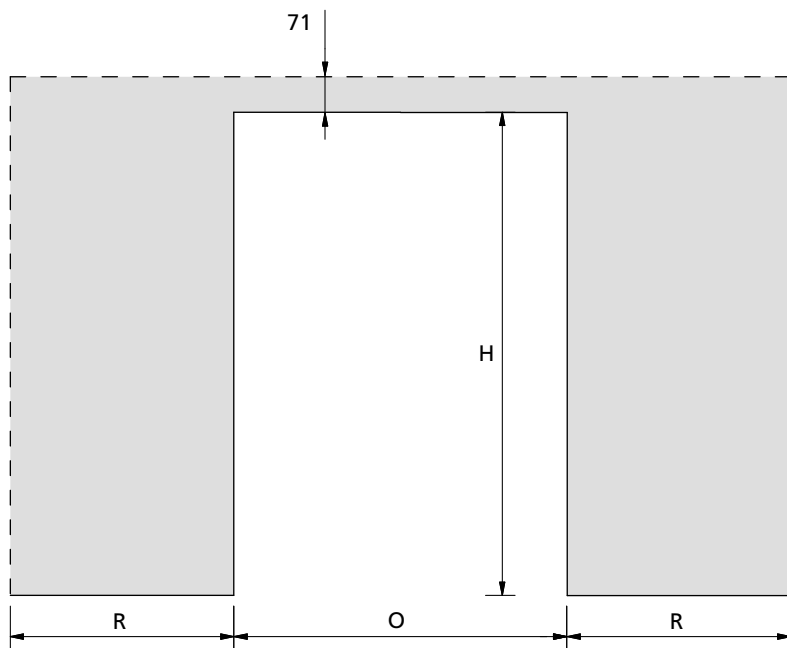

Dimensions de la porte - Abmessungen von Türen - Dimensions of doors - Dimensiones de las puertas

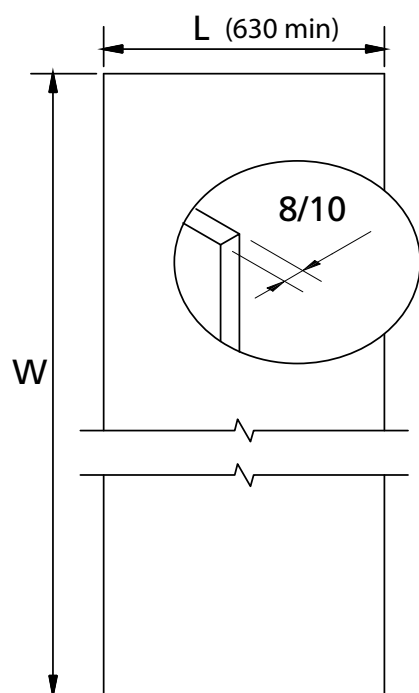

### ESG EN 12150

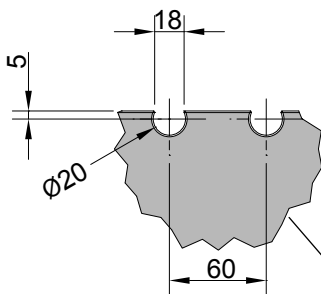

Réf. Kit Set nb / Art.-Nr.	L	W	B
<b>GB0110</b>	$(O / 2) + 42$	$H + 15$	450
<b>GB0112</b>	$(O / 2) + 42$	$H + 15$	540
<b>GB0114</b>	$(O / 2) + 42$	$H + 15$	660
<b>GB0116</b>	$(O / 2) + 42$	$H + 15$	660
<b>GB0118</b>	$(O / 2) + 42$	$H + 15$	660
<b>GB0120</b>	$(O / 2) + 42$	$H + 15$	660

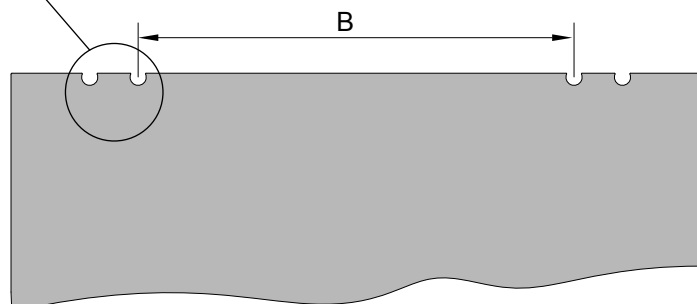

## FIXATION AU PLAFOND FIXING ON THE CEILING DECKENBEFESTIGUNG MONTAJE FIJACIÓN AL TECHO

Réf. Kit Set nb / Art.-Nr.	O	R
GB0110	$1330 \leq O < 1530$	$(3004 - O) / 2$
GB0112	$1530 \leq O < 1730$	$(3404 - O) / 2$
GB0114	$1730 \leq O < 1930$	$(3804 - O) / 2$
GB0116	$1930 \leq O < 2130$	$(4204 - O) / 2$
GB0118	$2130 \leq O < 2330$	$(4604 - O) / 2$
GB0120	$2330 \leq O < 2530$	$(5004 - O) / 2$

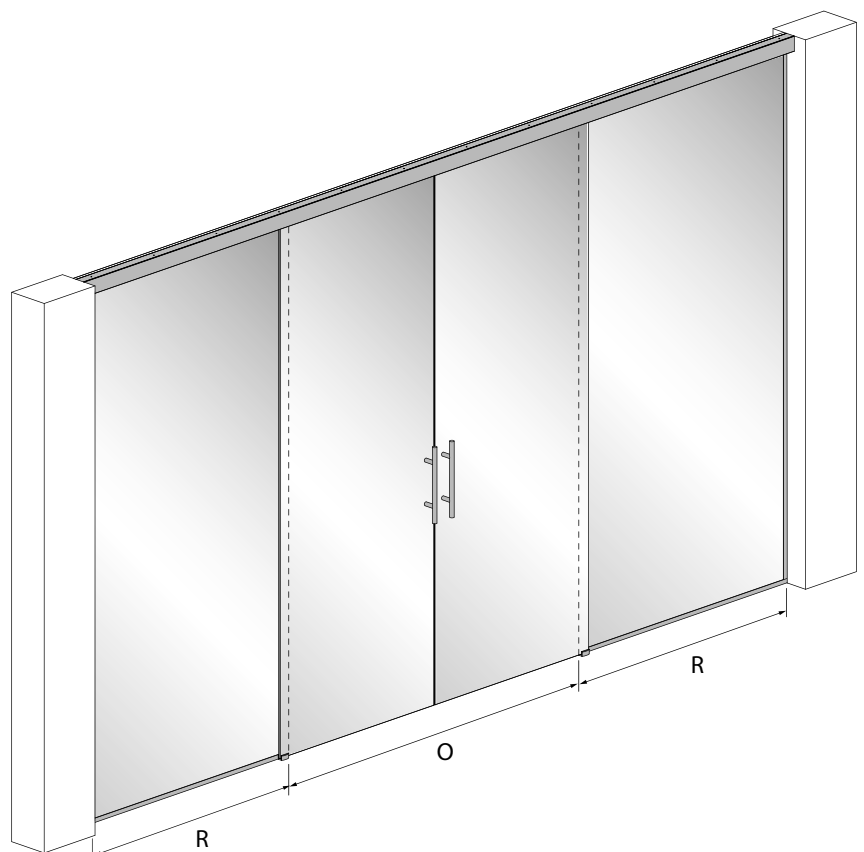
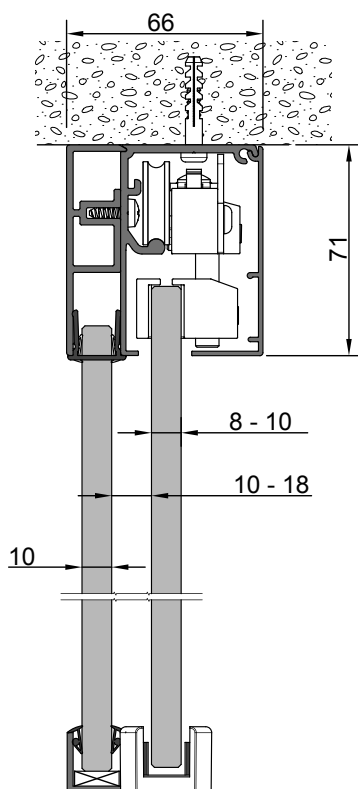
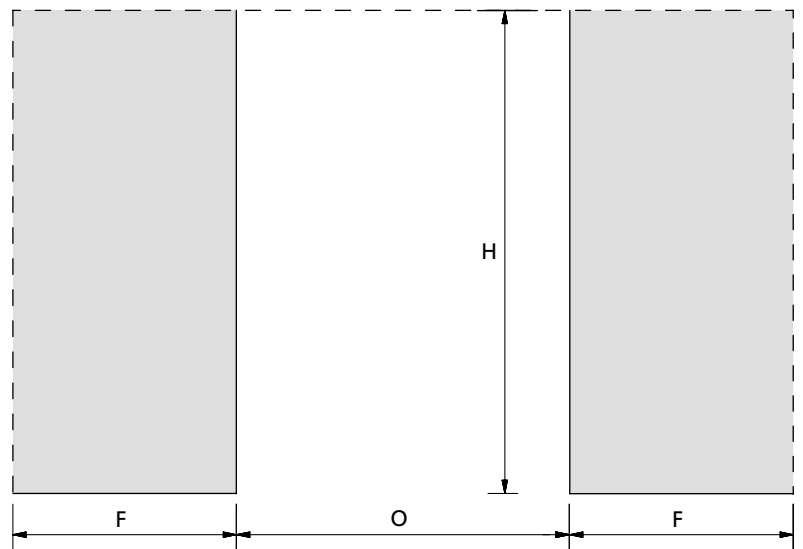
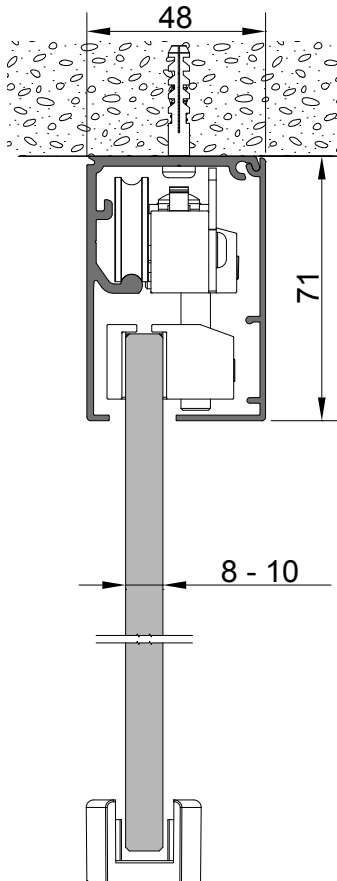

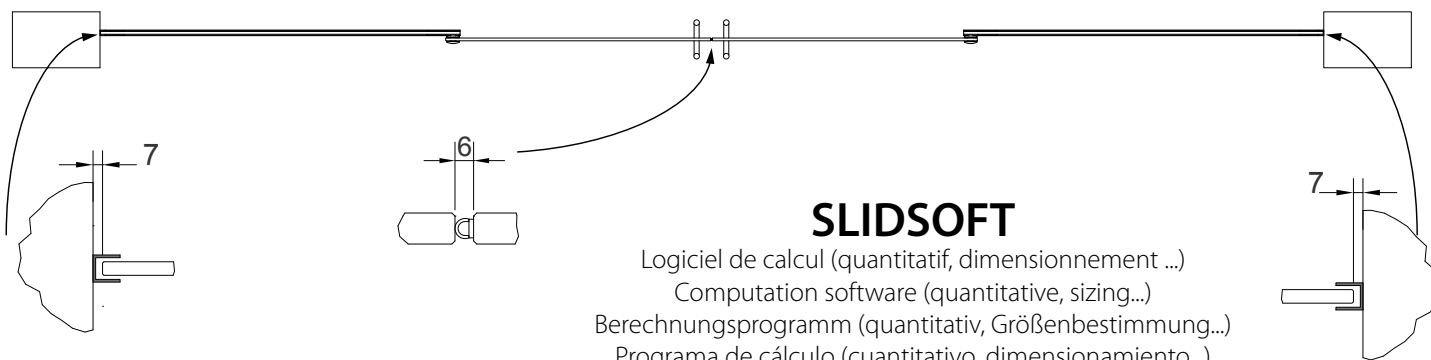
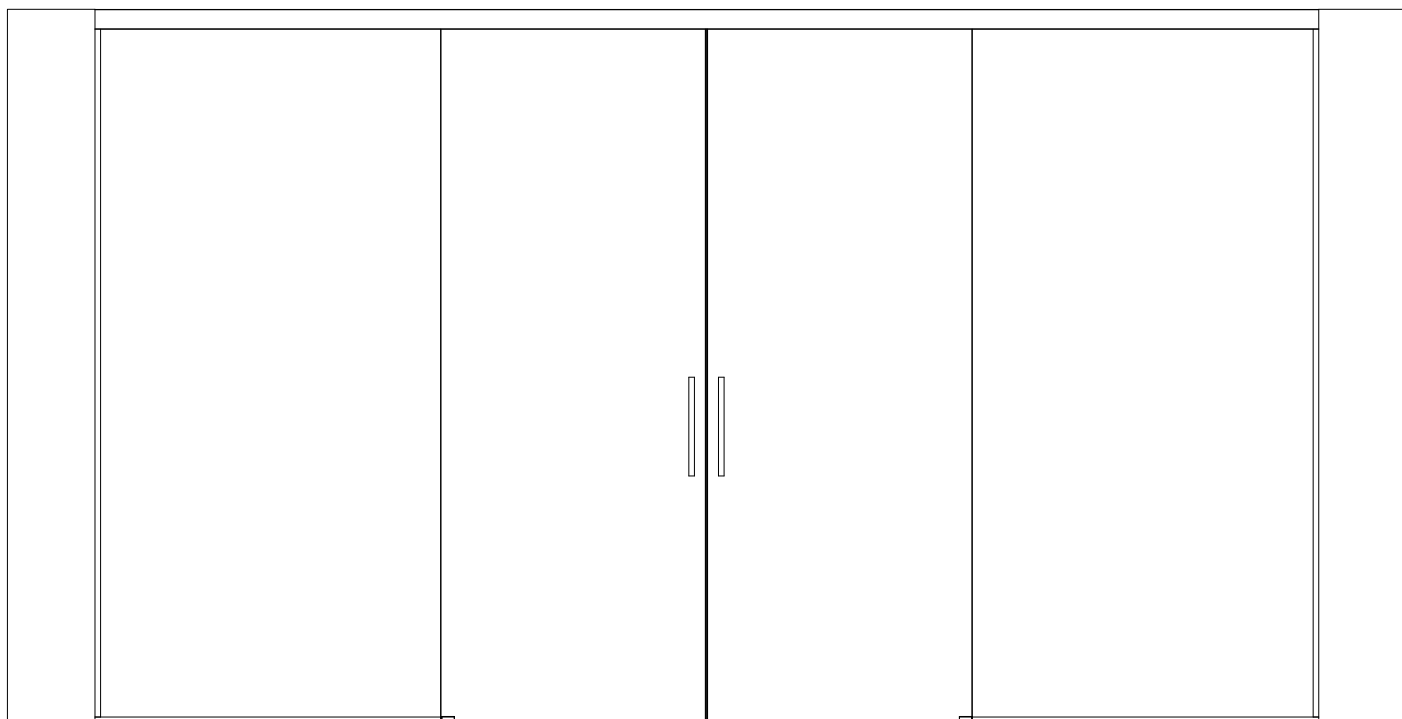
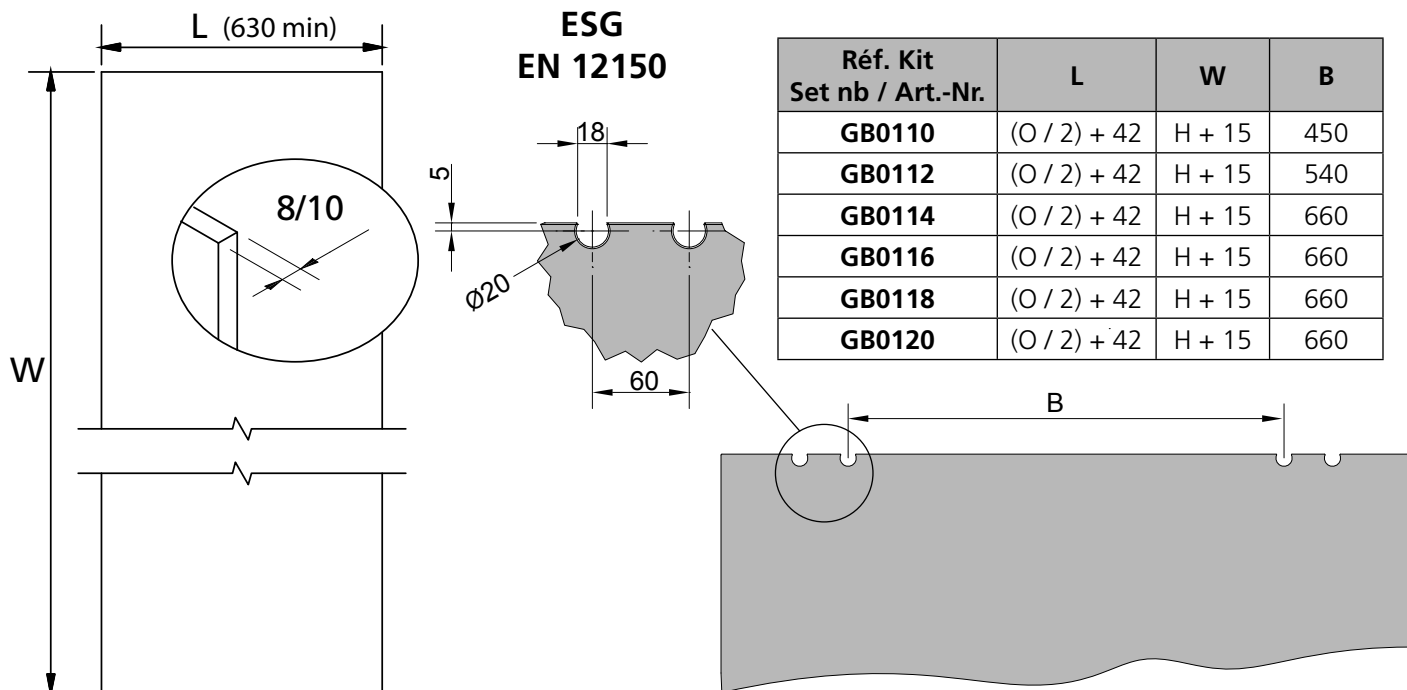

### SLIDSOFT

Logiciel de calcul (quantitatif, dimensionnement ...)  
 Computation software (quantitative, sizing...)  
 Berechnungsprogramm (quantitativ, Größenbestimmung...)  
 Programa de cálculo (cuantitativo, dimensionamiento...)

[www.mantion.com](http://www.mantion.com)

1.

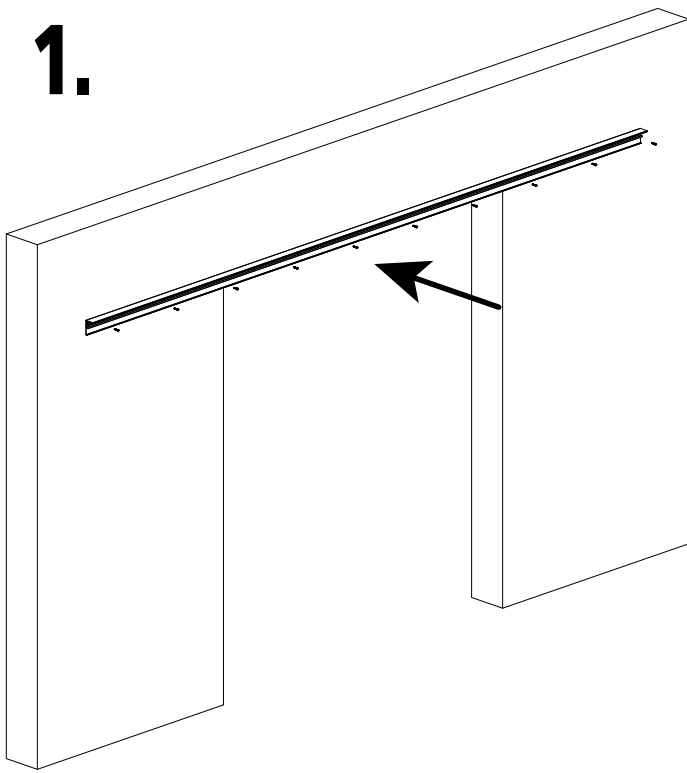

OU  
OR  
ODER

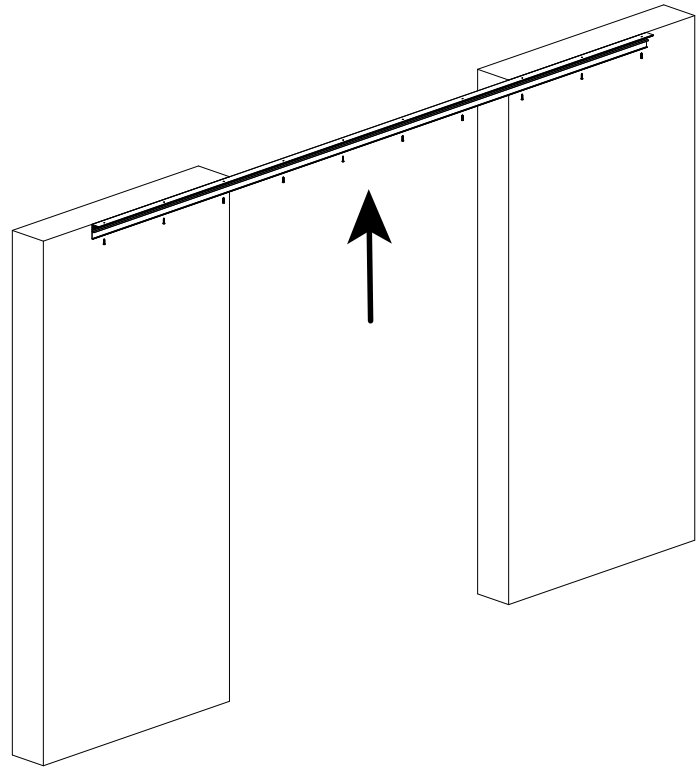

# 1.bis - OPTION

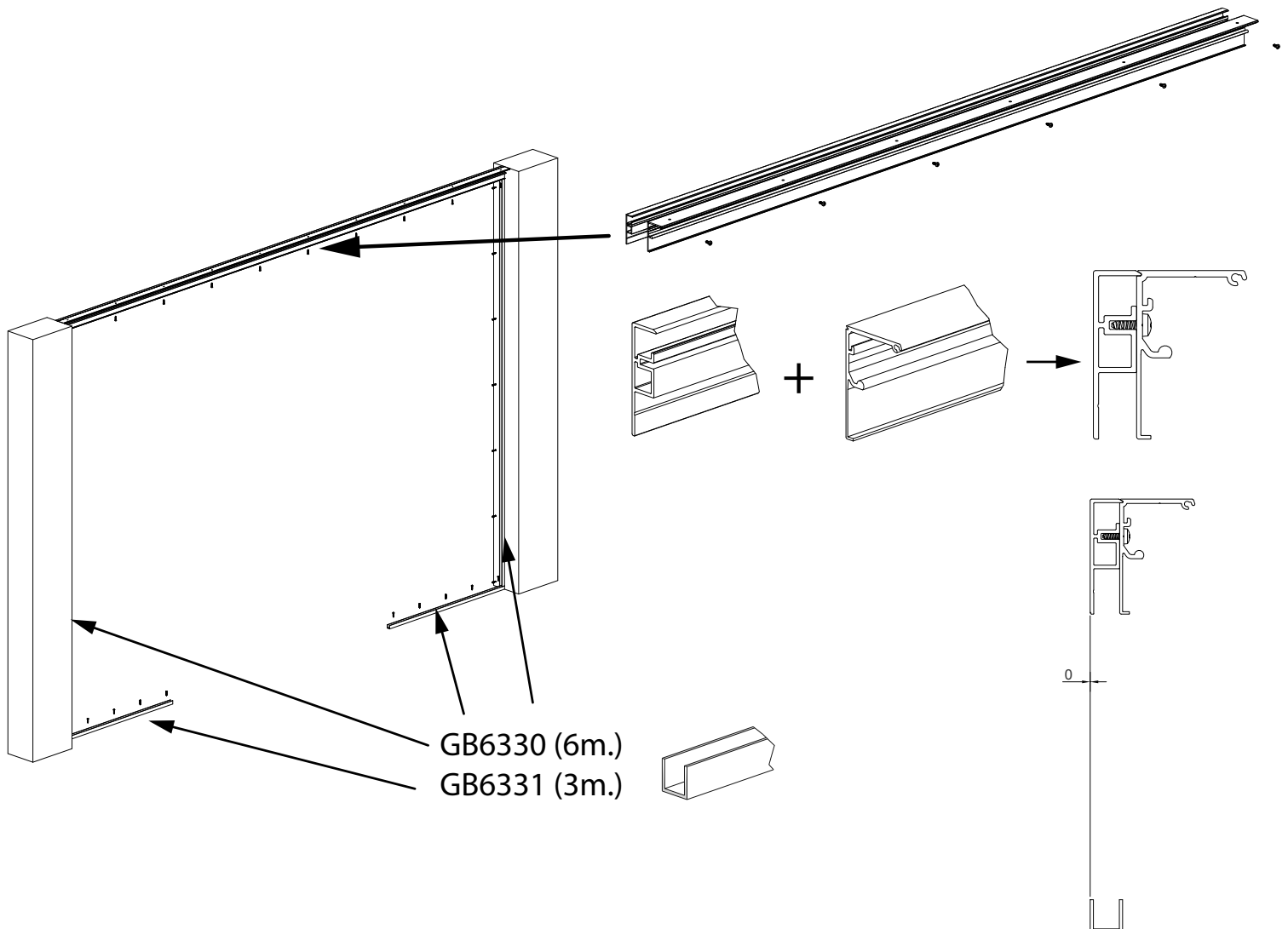

GB6330 (6m.)  
GB6331 (3m.)

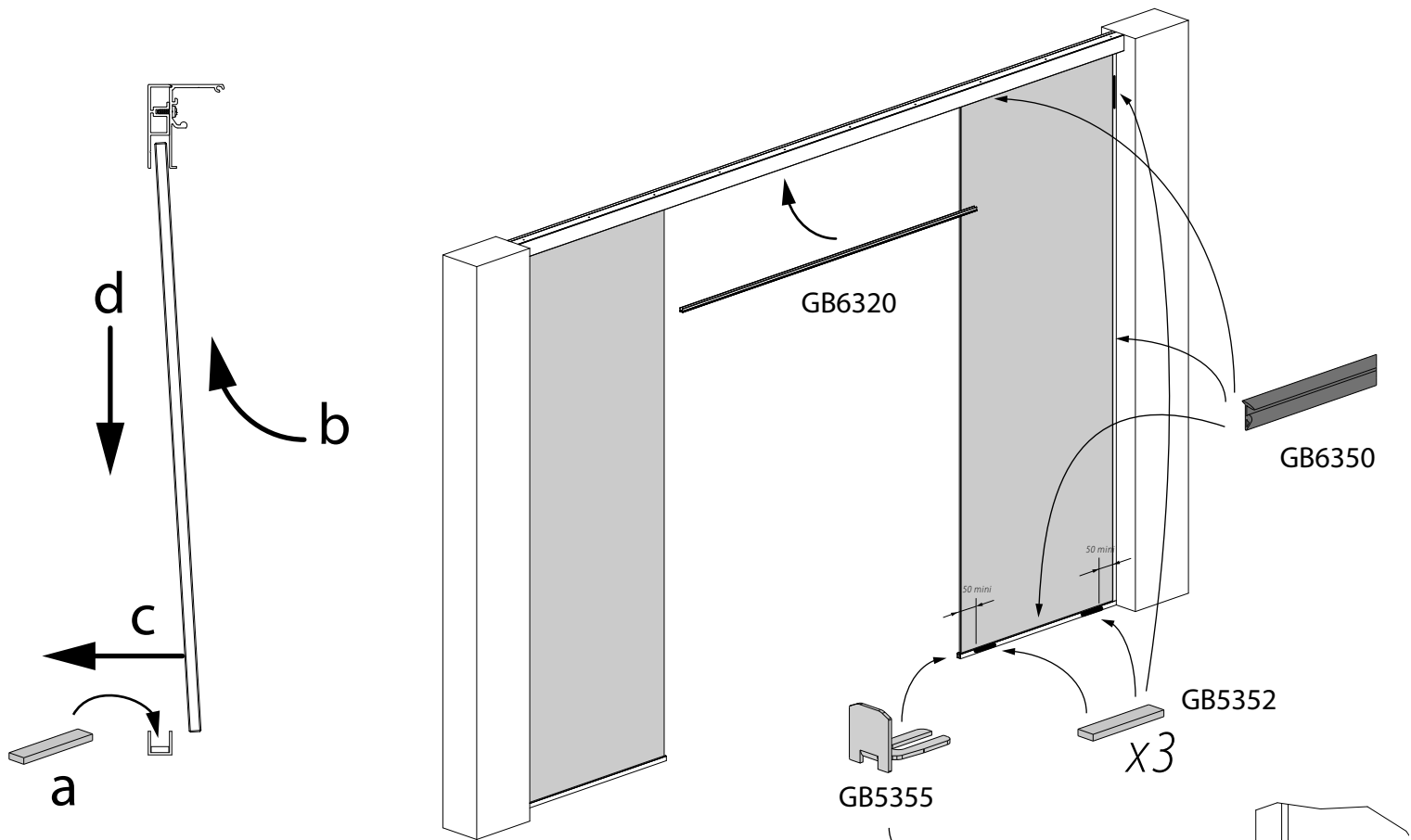

**2.**

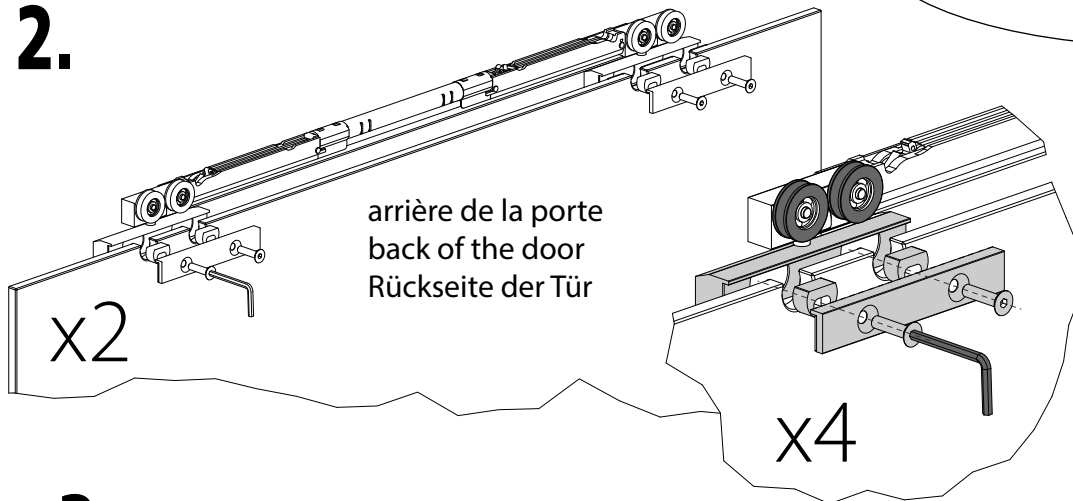

**3.**

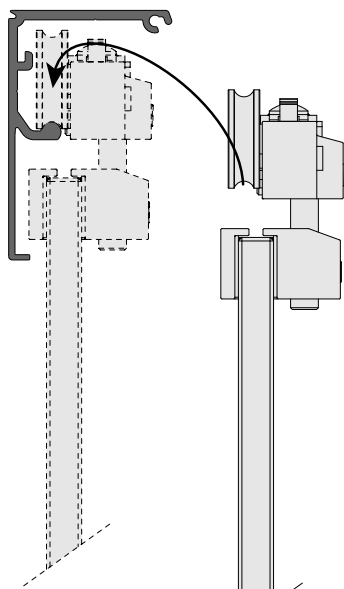

**4.**

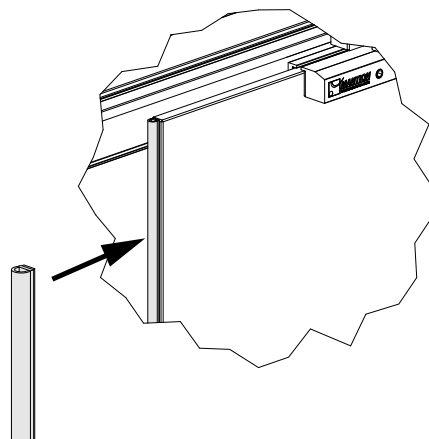

**5.**

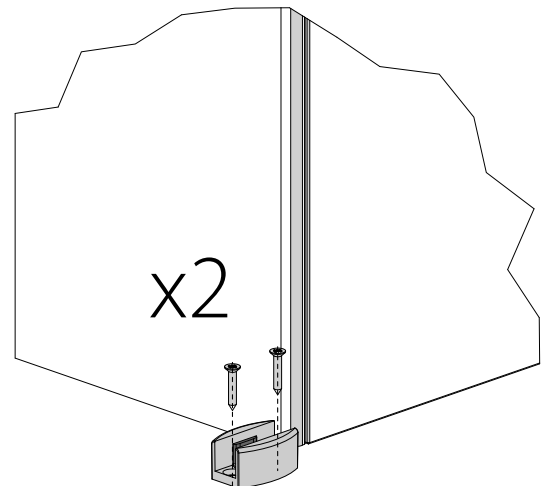

6.  x4

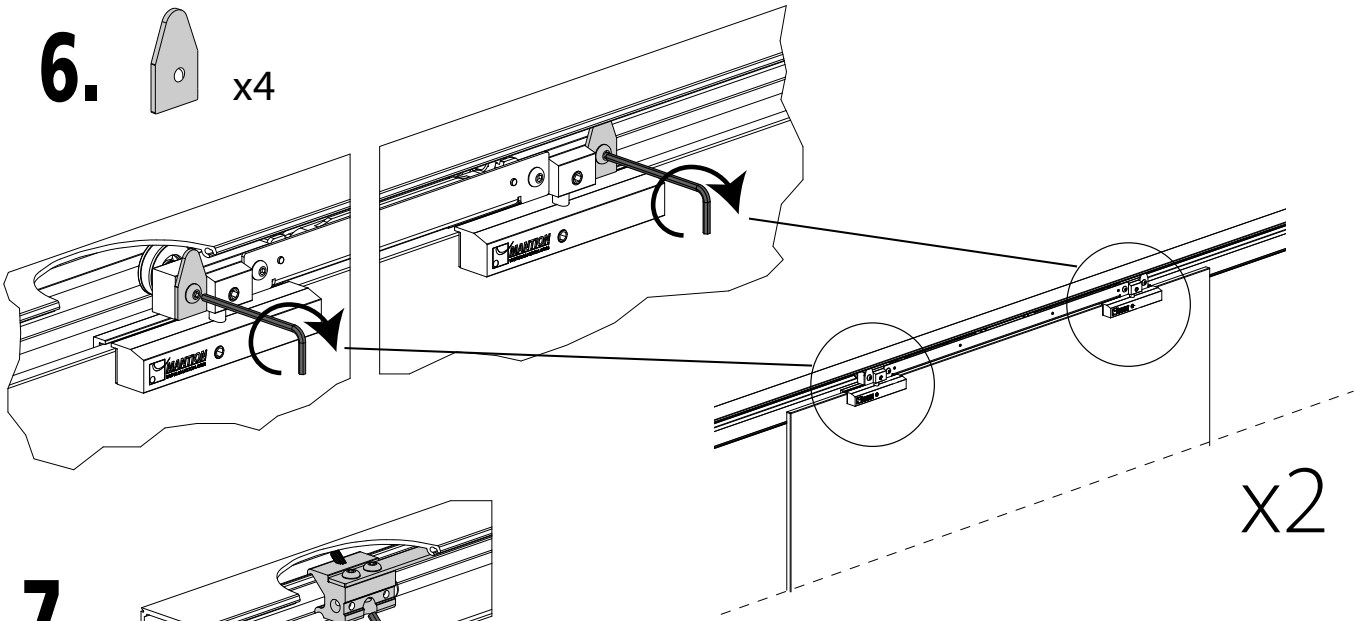

7.

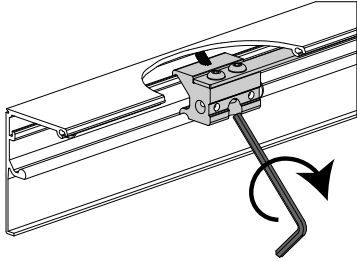

GB5002 & GB5004

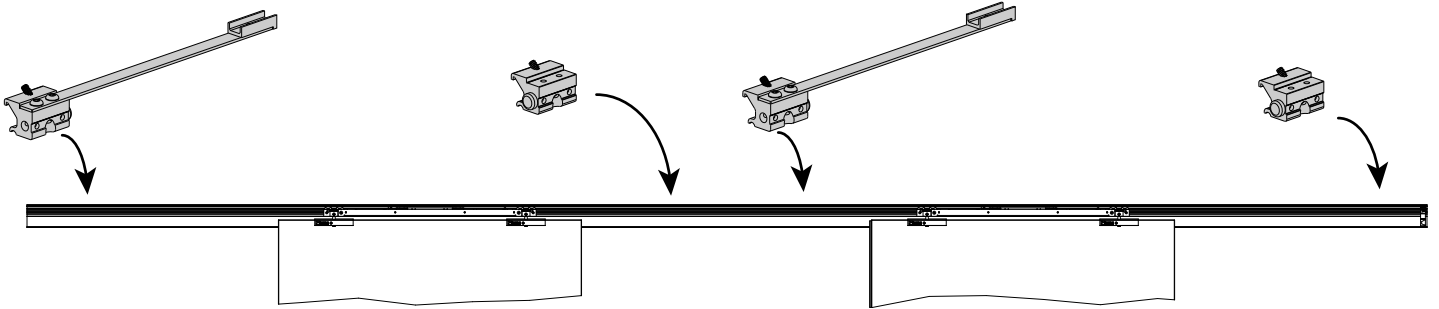

GB5003

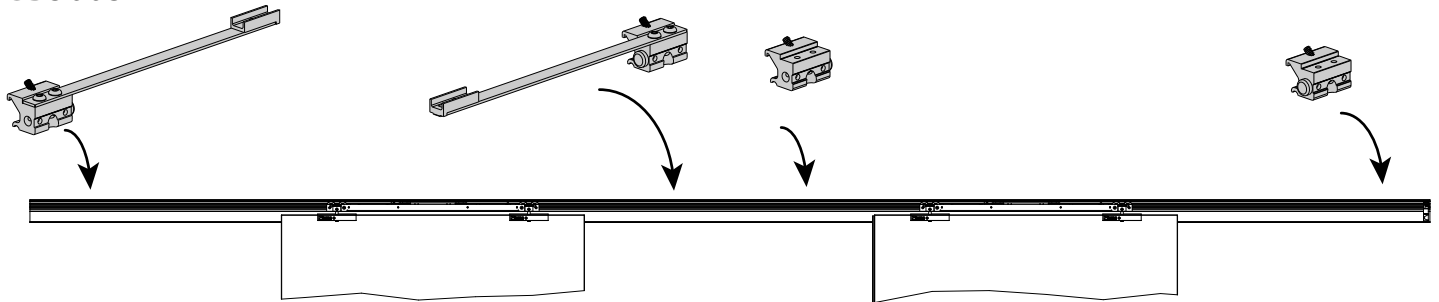

8.

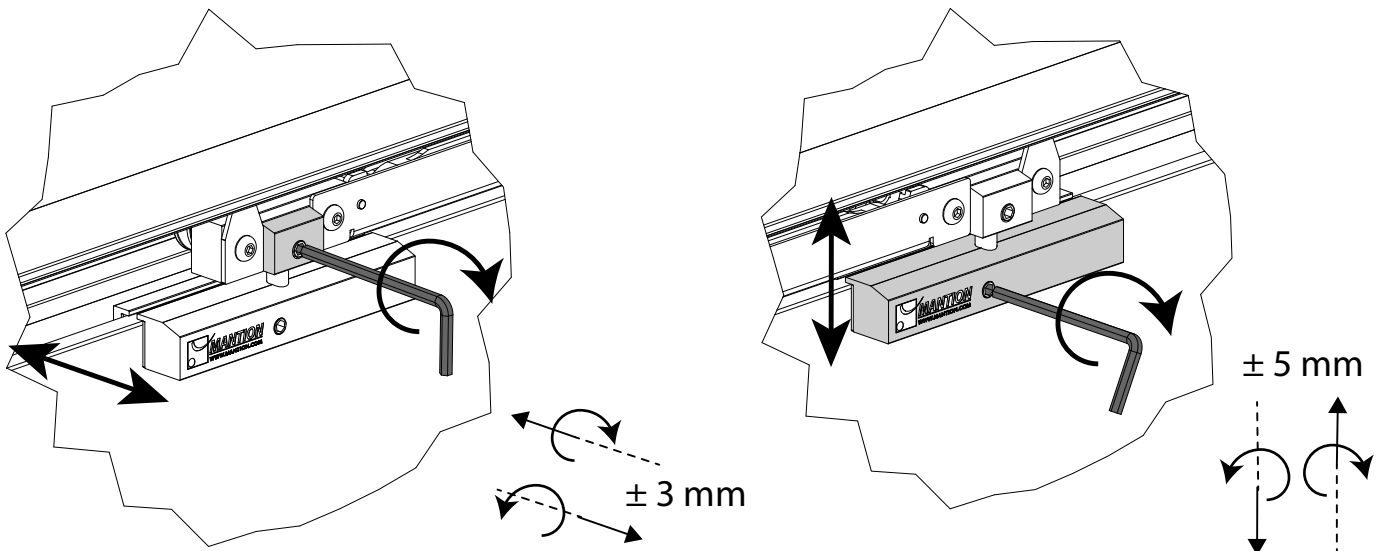



9.

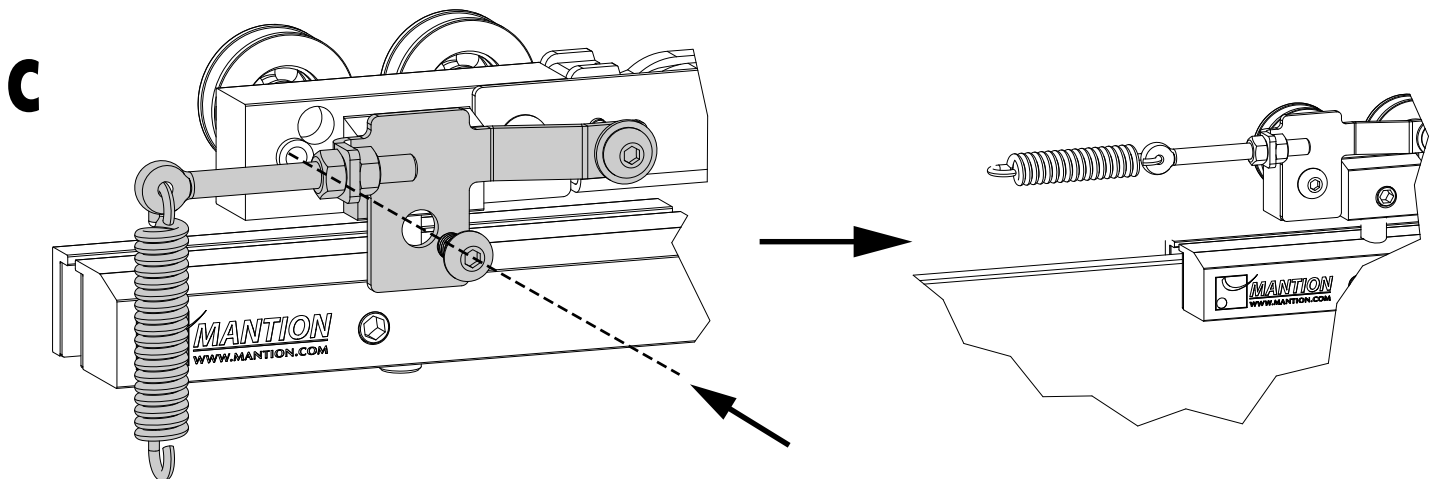
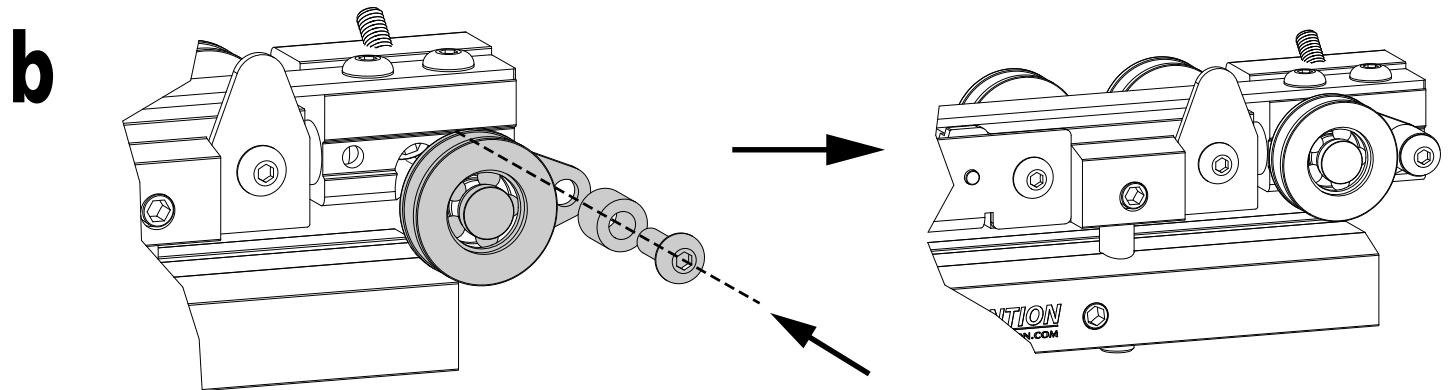
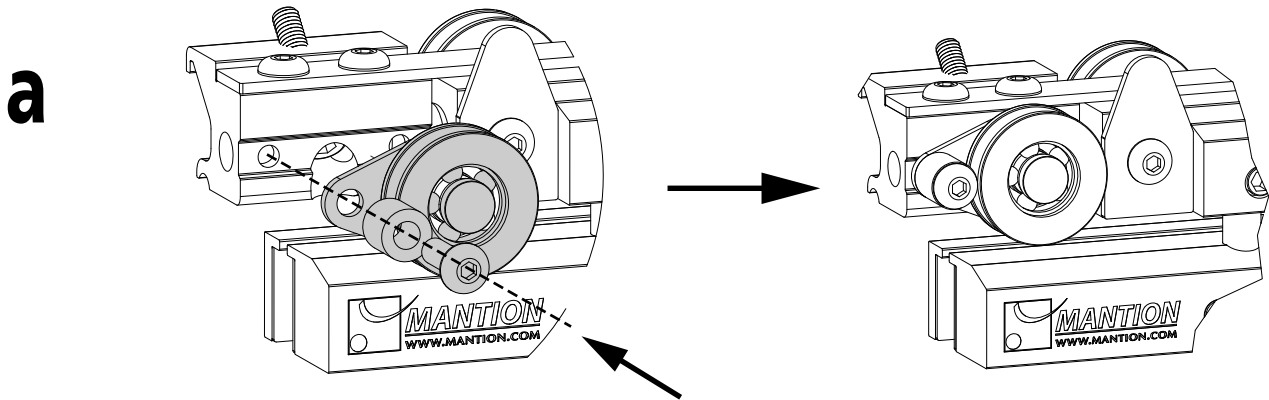
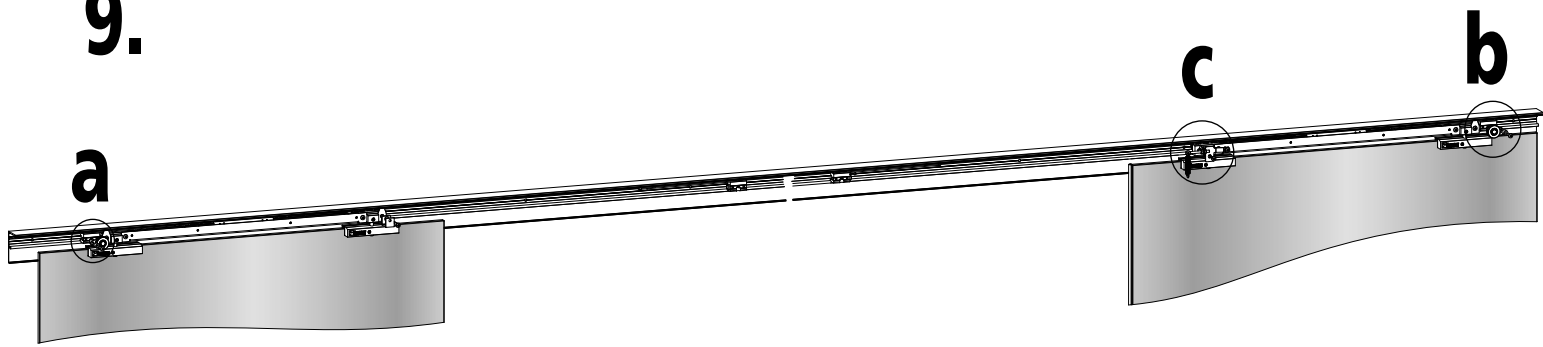

10.

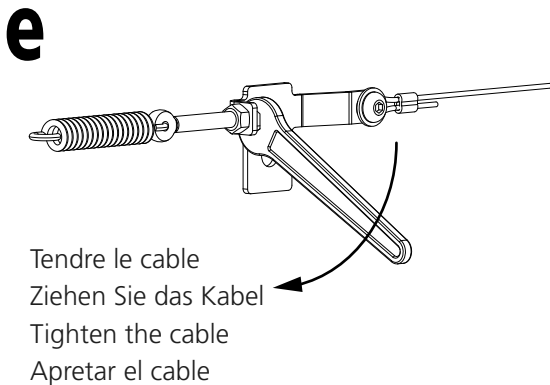
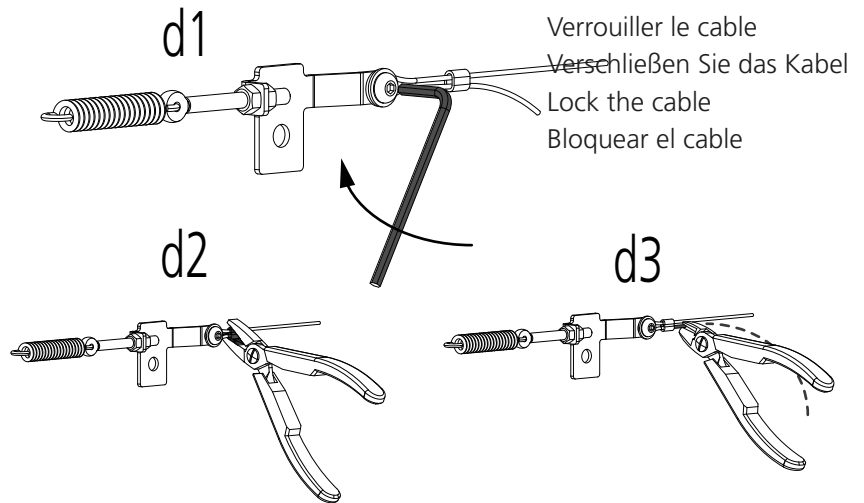
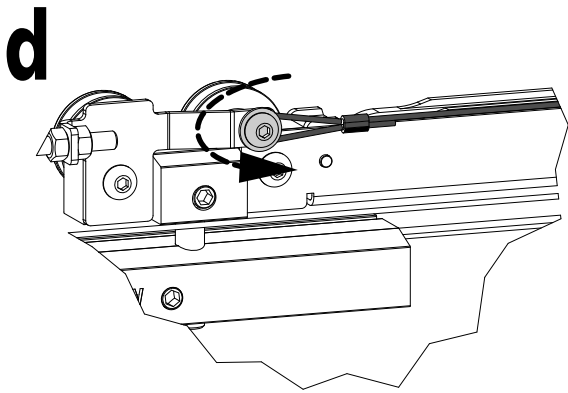
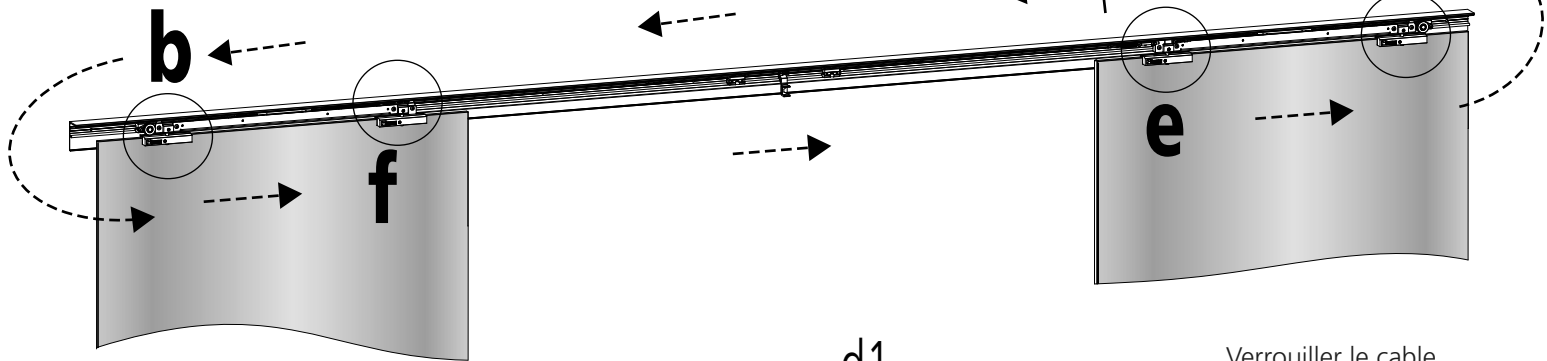
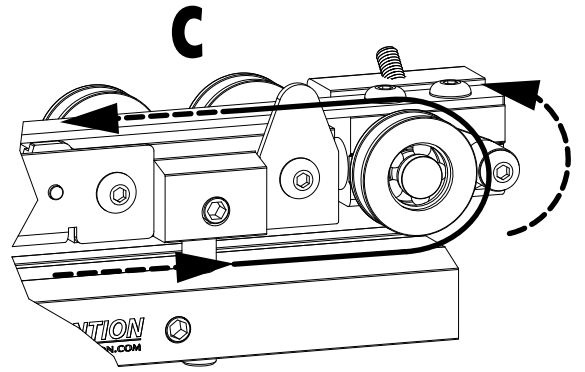
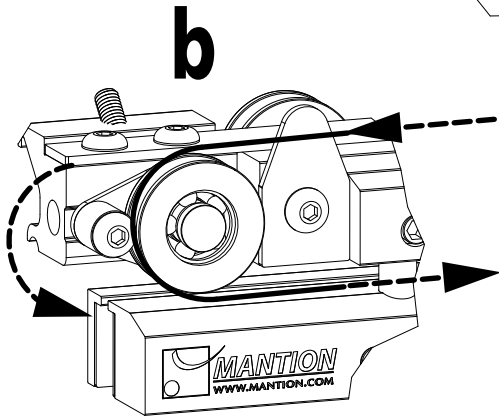
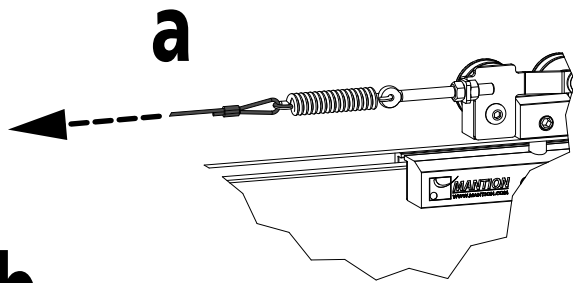

Verrouiller le cable lorsque les panneaux sont en position ouverte  
 Verriegeln wenn die flügel geöffnet sind  
 Lock when the panels are open  
 Bloquear el cable cuando las hojas están en posición abierta

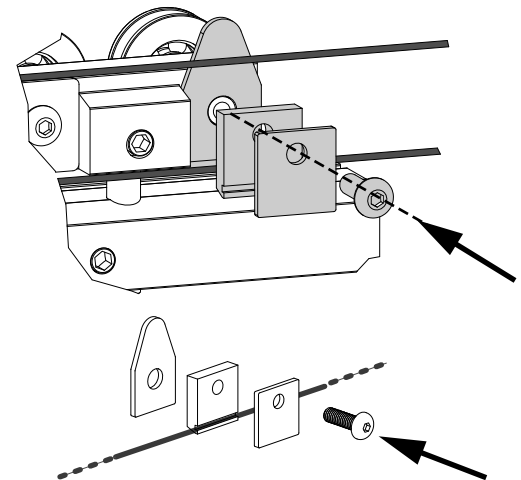

# 11.

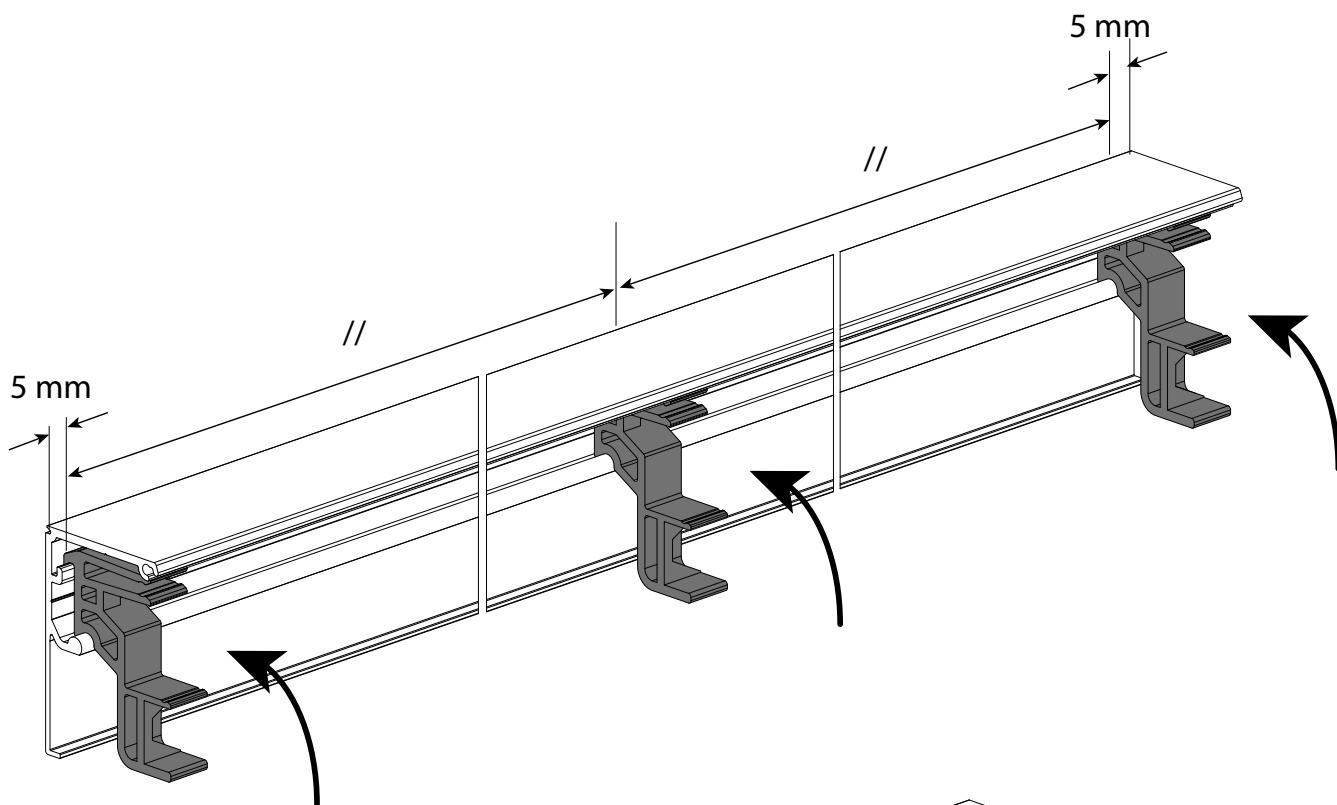

# 12.

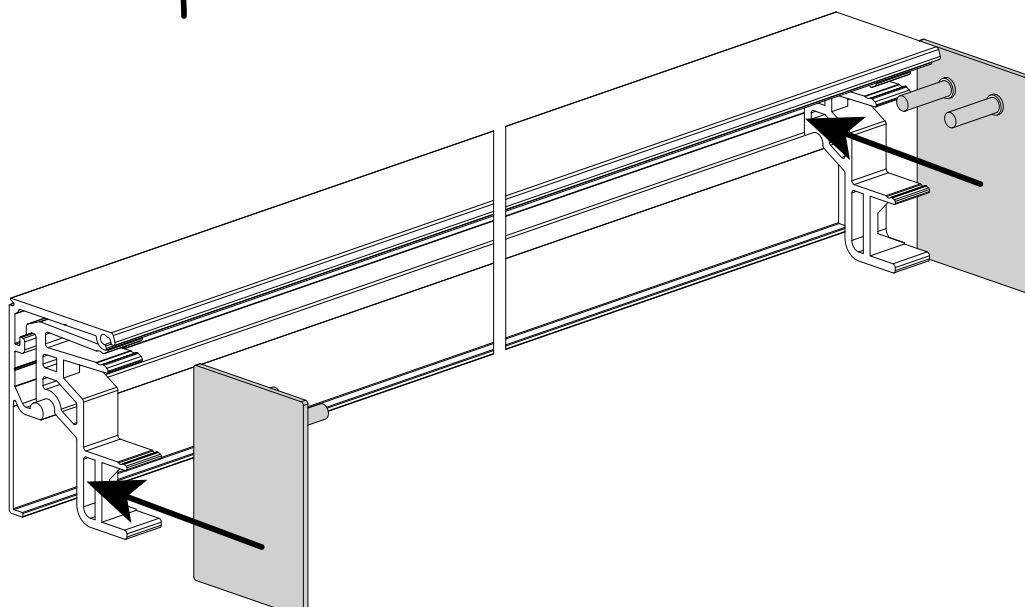

# 13.

