



INSTRUCTION DE MONTAGE  
MONTAGEANLEITUNG  
INSTRUCTIONS FOR ASSEMBLY  
INSTRUCCIONES DE MONTAJE

# SAF-TELESCOPIC

## NM\_SAFTL\_007

Poids maximal des panneaux Maximales Gewicht Maximum weight Peso máximo	80 KG 180 lbs.
Epaisseur des panneaux Ladendicke Shutter thickness Espesor de las contraventanas	38 - 40 mm 1 1/2" - 1 9/16"
Largeur maximale des panneaux Maximale Flügelbreite Maximum panel width Ancho máximo de panel	700 - 1500 mm 27" - 59"

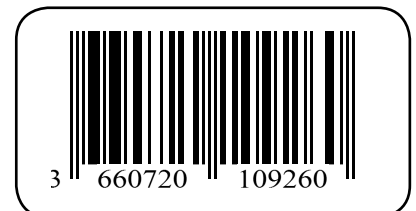
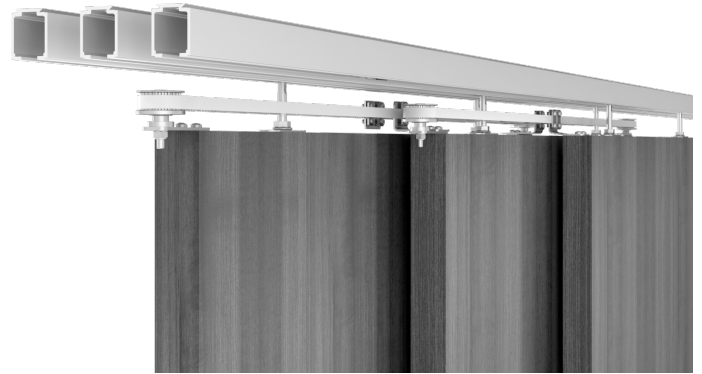

# COMPOSITION - ZUSAMMENSETZUNG - COMPOSICIÓN

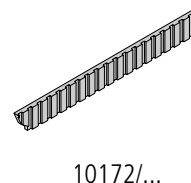
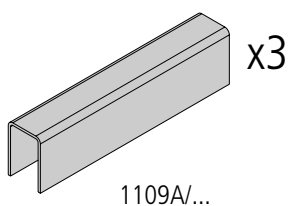
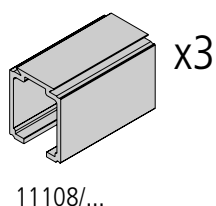

## SAF80-TELESCOPIC

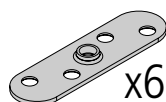
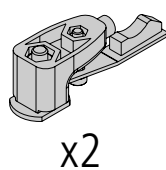
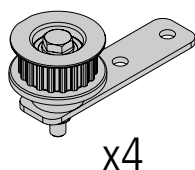
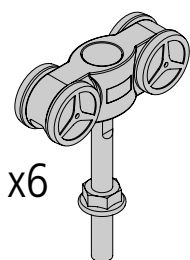

## 1102TL3

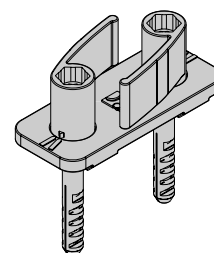
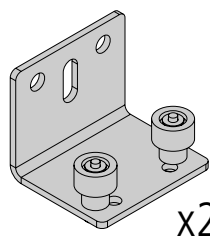

## 10190S13

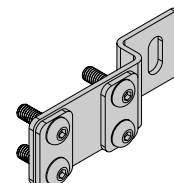
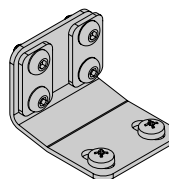
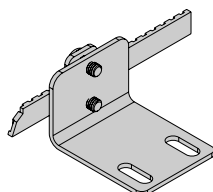
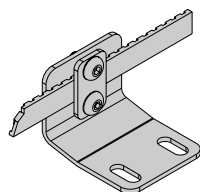

## CONDITIONS DE POSE / MONTAGEBEDINGUNGEN / INSTALLATION REQUIREMENTS / CONDICIONES DE COLOCACION:

- Produit destiné à une utilisation en intérieur / Dieses Produkt ist nur für Innenanwendung geeignet / For indoor use only / Producto para utilización en interior
- Ne pas installer dans des endroits humides / Nicht in feuchten Atmosphären verwenden / Do not install in humid places / No instalar en lugares húmedos
- Le montage doit être effectué par des monteurs qualifiés / Die Montage muss von qualifizierten Handwerkern geführt werden / Installation must be performed by skilled personnel / el montaje tiene que hacerse por instaladores cualificados

## DIMENSIONS / MASSE / SIZING / DIMENSIONES (mm):

- Epaisseur panneau / Paneelstärke / Panel thickness / Grueso del panel: **38 -40 mm**
- Poids panneau / Paneelgewicht / Panel weight / Peso panel: **80 Kg MAX**

38 mm - 1 1/2" / 40 mm - 1 9/16"

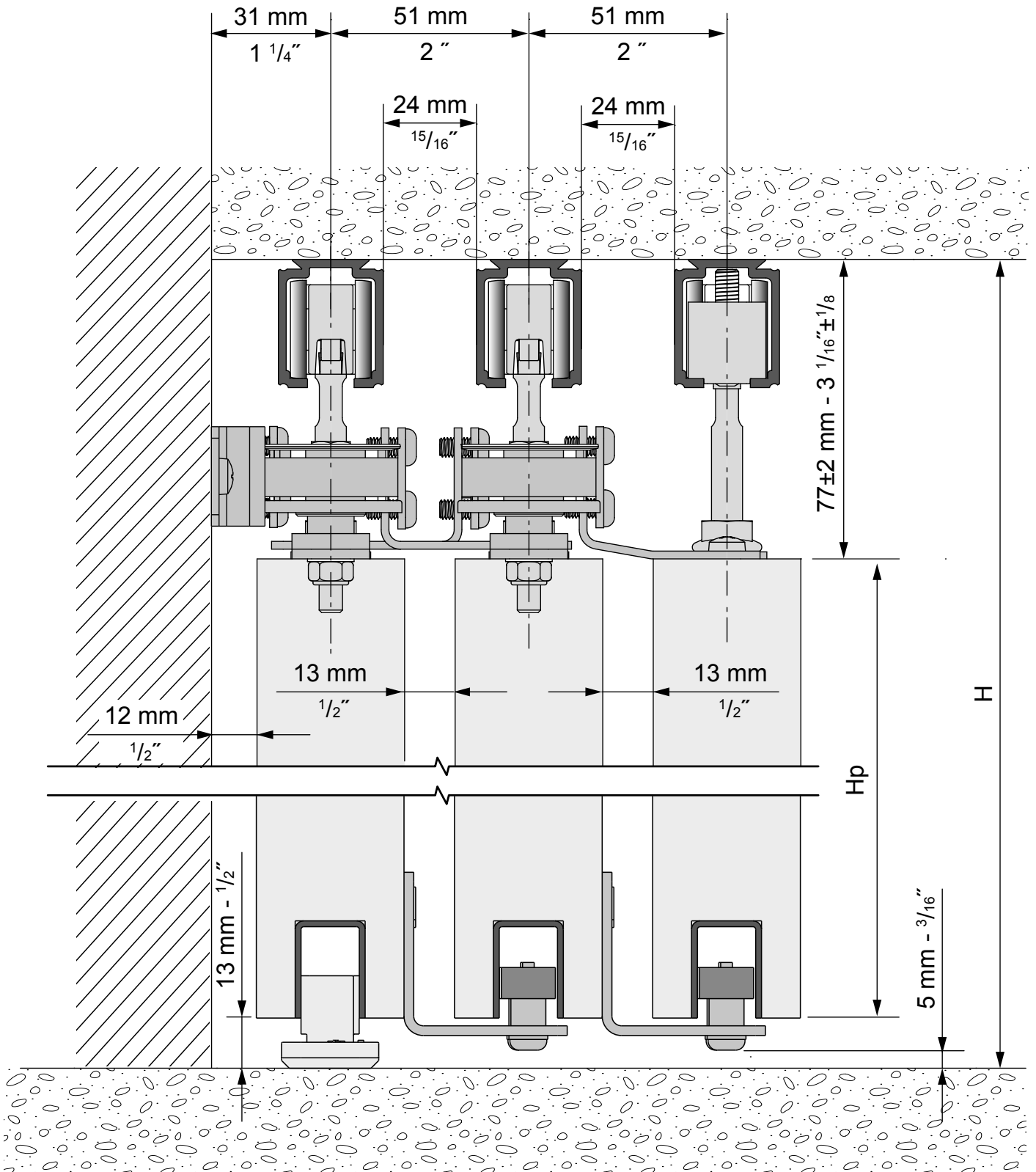

H = Hauteur de baie  
Opening height  
Öffnungshöhe  
Altura de luz

Hp = Hauteur panneaux  
Door height  
Schiebetürhöhe  
Altura de panel

$$H_p = H - 90 \text{ mm} = \text{_____ mm}$$

$$H_p = H - 3 \frac{1}{2} \text{''} = \text{_____''}$$

# PLANIFICATION - PLANUNG - PLANNING - PLANIFICACIÓN



$$R = 90 \text{ mm} \quad L_p = \frac{(3 \times R) + LO}{3} = \text{_____ mm}$$

$$3 \frac{1}{2}'' \quad LR = LO + L_p = \text{_____ mm}$$

$700 \leq L_p \leq 1500$   
 $27'' \leq L_p \leq 59''$   
 $LR \leq 6000$   
 $LR \leq 235''$

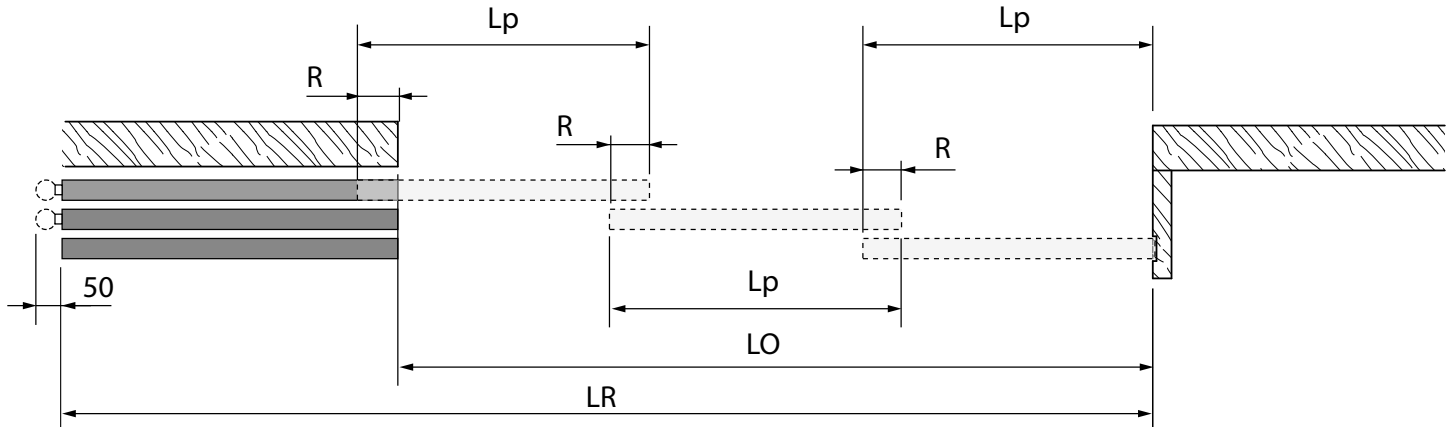

$$R = 90 \text{ mm} \quad L_{p1} = \frac{(3 \times R) + (LO - P)}{3} = \text{_____ mm}$$

$$3 \frac{1}{2}'' \quad L_{p2} = L_{p1} + P = \text{_____ mm}$$

$$P = 90 \text{ mm} \quad LR = LO + L_{p1} = \text{_____ mm}$$

$$3 \frac{1}{2}''$$

$700 \leq L_{p1} \leq 1500$   
 $27'' \leq L_{p1} \leq 59''$   
 $LR \leq 3000$   
 $LR \leq 235''$

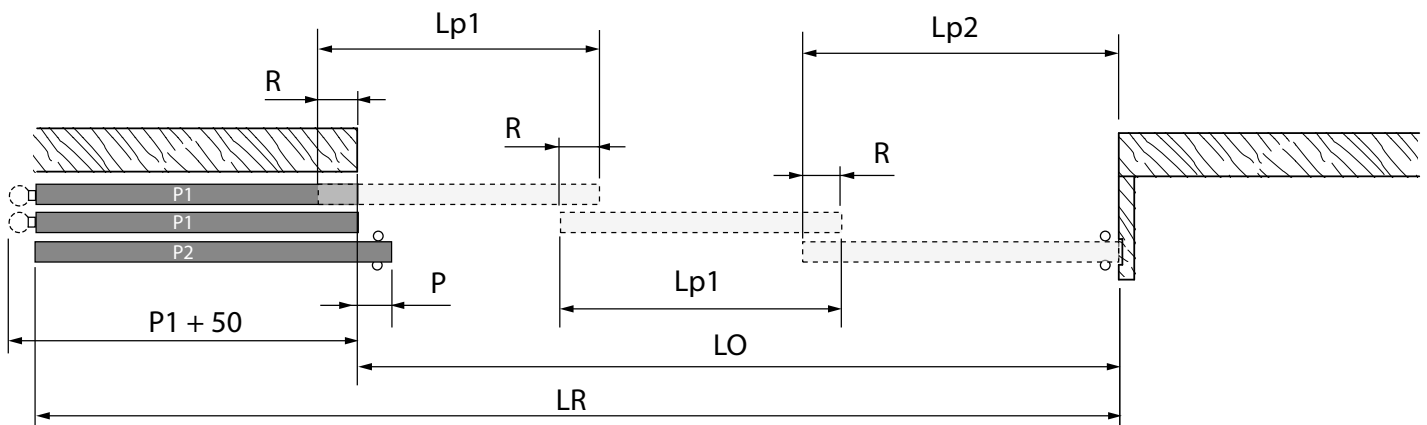

**LO** = Largeur de baie  
Opening width  
Öffnungsbreite  
Ancho de luz

**Lp** = Largeur panneaux  
Door width  
Schiebetürbreite  
Ancho de panel

**LR** = Longueur de rails  
Length of tracks  
Länge von Laufshienen  
Longitud de los perfiles

**R** = Recouvrement  
Door overlap  
Türübershneidung  
Recubrimiento

**P** = Poignée baton  
Sliding door handle  
Schiebetürgriffe  
Tirador

**PRÉPARATION DES PANNEAUX - PANELS PREPARATION  
VORBEREITUNG DER FLÜGEL - PREPARACIÓN DE LAS HOJAS**

**1.**

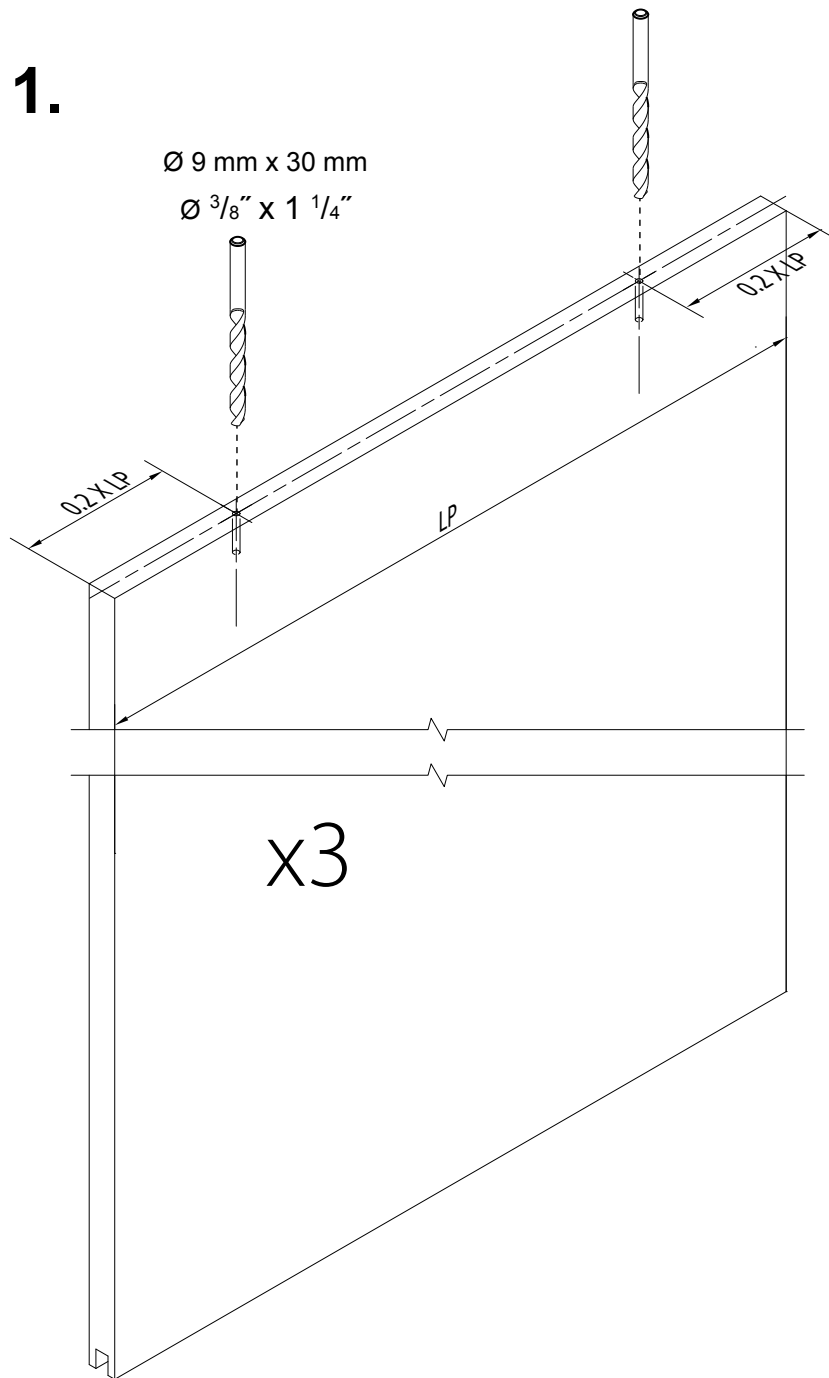

**1109 A**

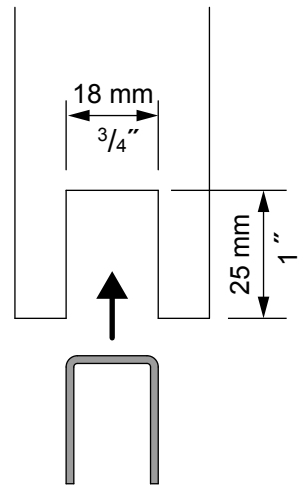

**1109**

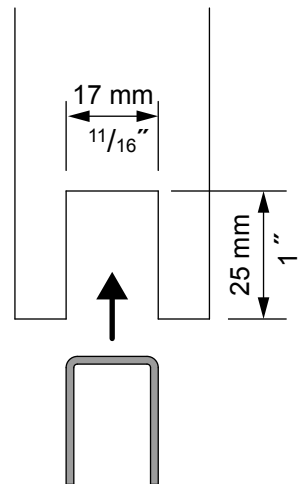

**2.**

**x4**

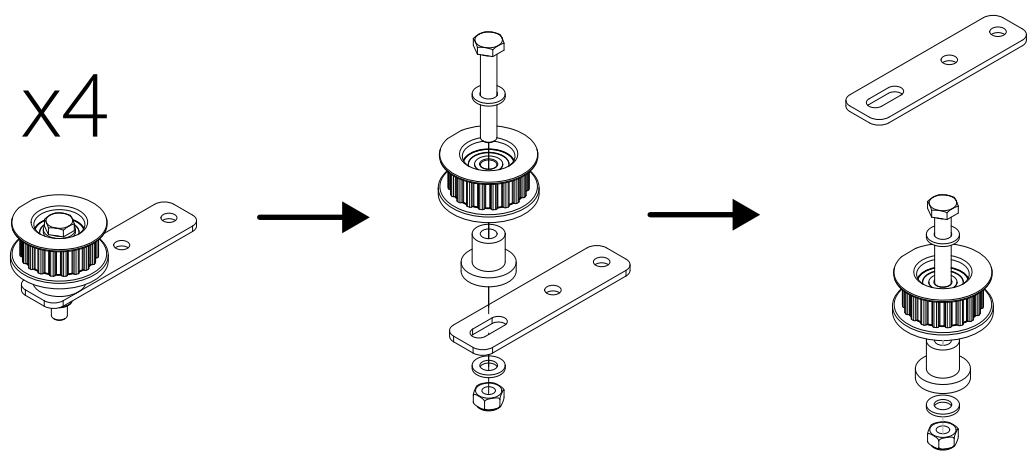

**PRÉPARATION DES PANNEAUX - PANELS PREPARATION  
VORBEREITUNG DER FLÜGEL - PREPARACIÓN DE LAS HOJAS**

**3.**

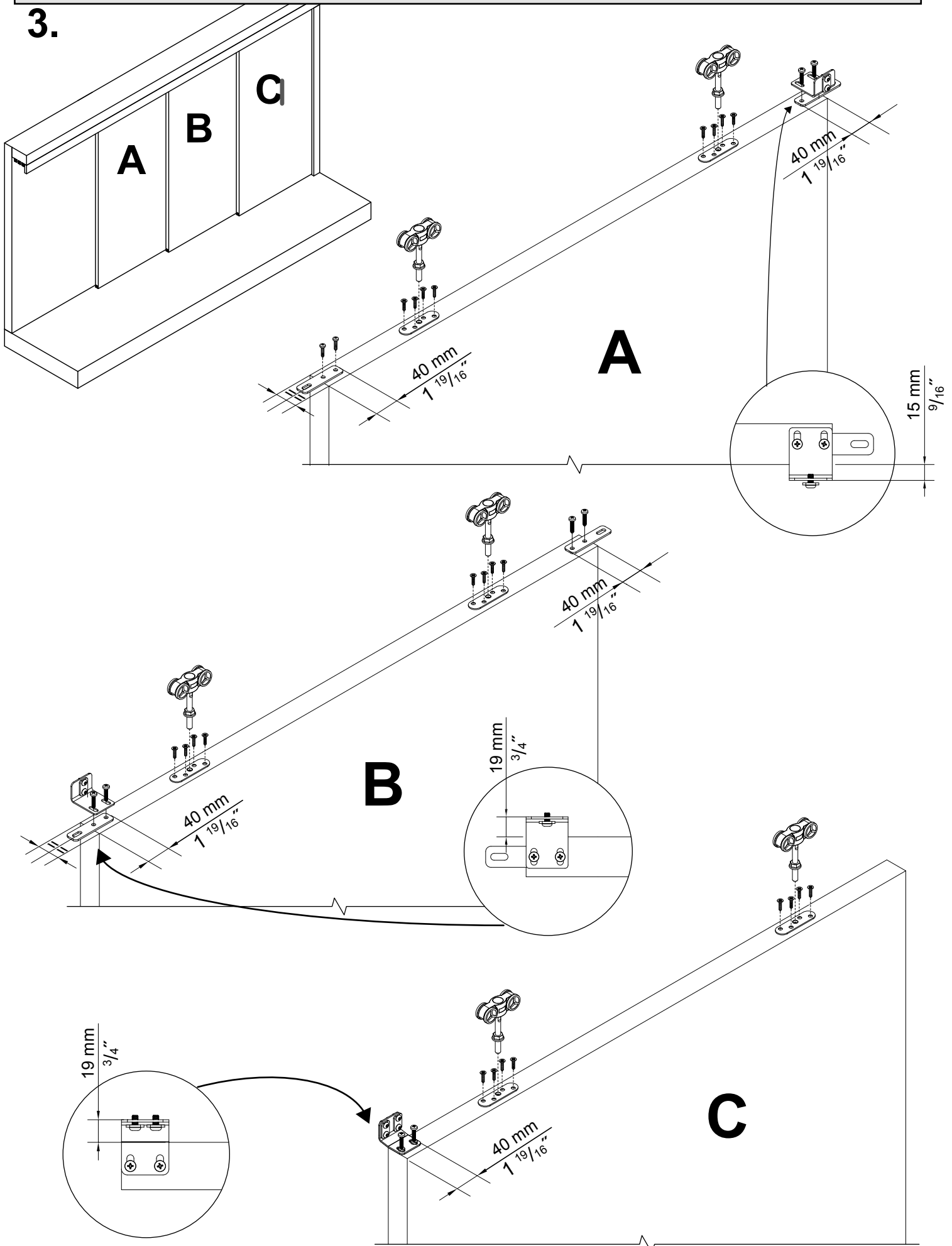

# MONTAGE - INSTALLATION - MONTAJE

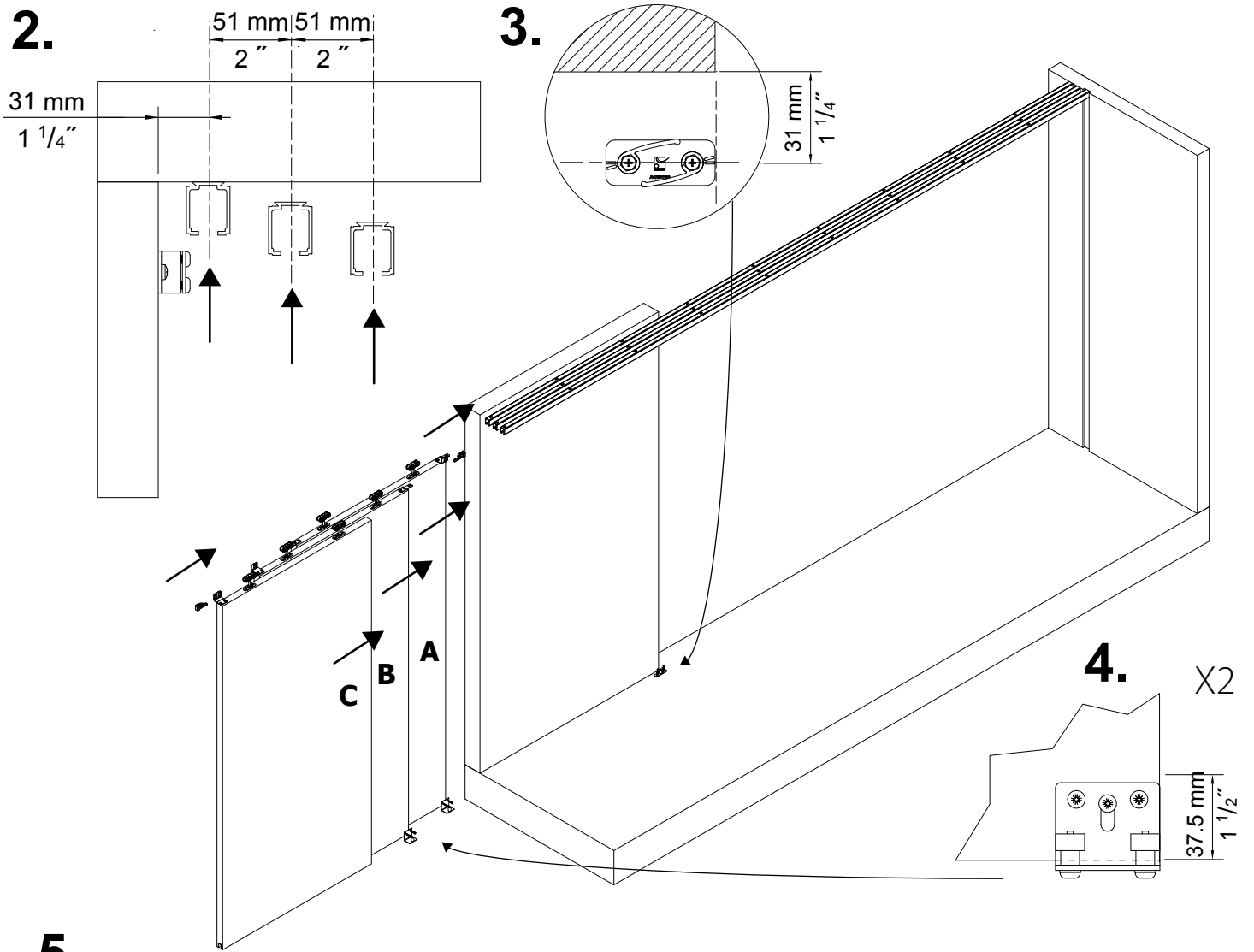
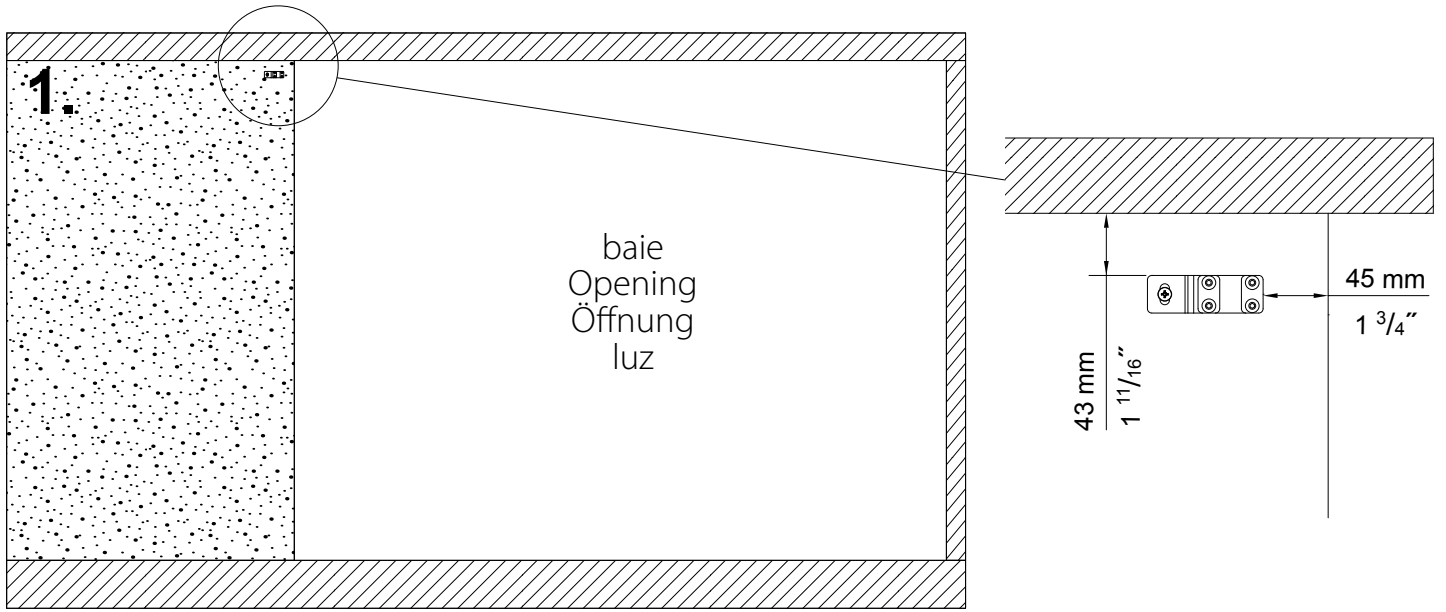

6.

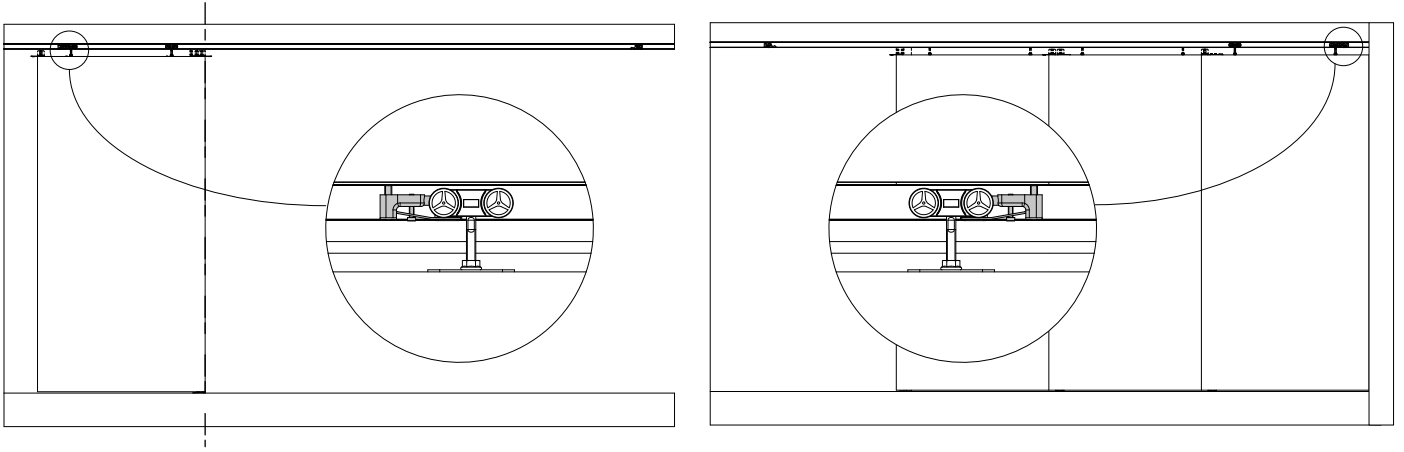

7.

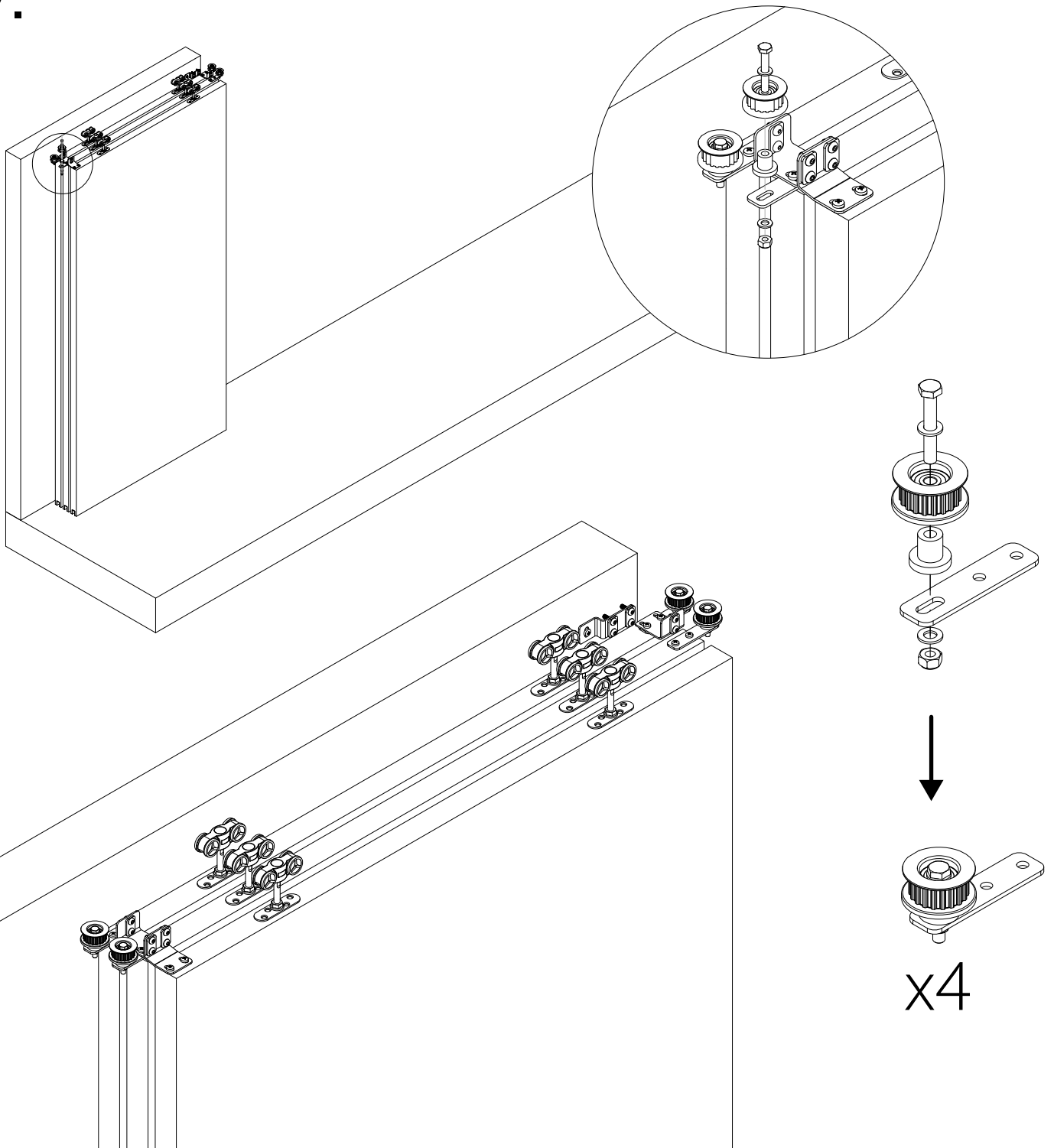



8.

